



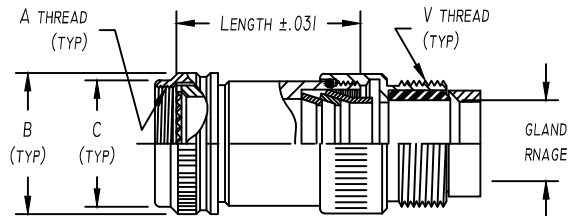
Table 2 - Cable Entry Data

| ENTRY ORDER NUMBER | ENVIRONMENTAL GLAND RANGE | | NON ENVIRONMENTAL CABLE RANGE | | V UNIFIED THREAD |
|--------------------|---------------------------|-------|-------------------------------|-------|------------------|
| | MAX | MIN | MAX | MIN | |
| 03 | .250 | .156 | .250 | .156 | .500-28 |
| 04 | .312 | .188 | .312 | .188 | .625-24 |
| 06 | .438 | .281 | .438 | .281 | .750-20 |
| 08 | .562 | .375 | .562 | .344 | .875-20 |
| 10 | .625 | .500 | .625 | .375 | 1.000-20 |
| 12 | .750 | .500 | .750 | .438 | 1.188-18 |
| 16 | .938 | .625 | .938 | .562 | 1.438-18 |
| 20 | 1.250 | .938 | 1.250 | .750 | 1.750-18 |
| 24 | 1.375 | 1.000 | 1.375 | .781 | 2.000-18 |
| 28 | 1.625 | 1.250 | 1.625 | .969 | 2.250-16 |
| 32 | 1.875 | 1.500 | 1.875 | 1.125 | 2.500-16 |

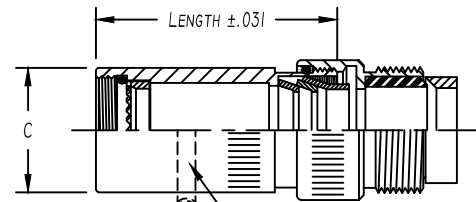
Table 3 - Length Code Data

| CONN CODE NUMBER | MIN ORDER LENGTH | MIN LENGTH CODE |
|------------------|------------------|-----------------|
| 18 | 1.250 | 05 |
| 19 | 1.750 | 07 |
| 21 | 1.250 | 05 |
| 30 | 1.500 | 06 |
| 32 | 1.750 | 09 |
| 40 | 1.250 | 05 |
| 41 | 1.250 | 05 |
| 47 | 1.250 | 05 |
| 51 | 1.250 | 05 |
| 54 | 1.250 | 05 |
| 61 | 1.500 | 06 |
| 76 | 1.250 | 05 |

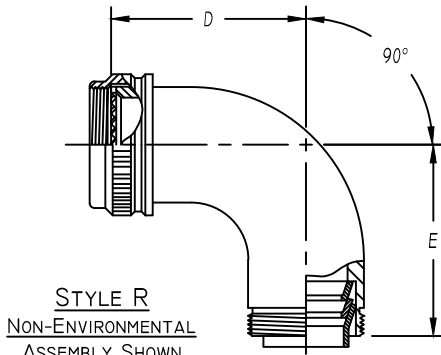
WHEN MAXIMUM CABLE ENTRY EXCEEDS THE CONNECTOR INTERFACE DIAMETER, A 2 PIECE ADAPTER WILL BE SUPPLIED.



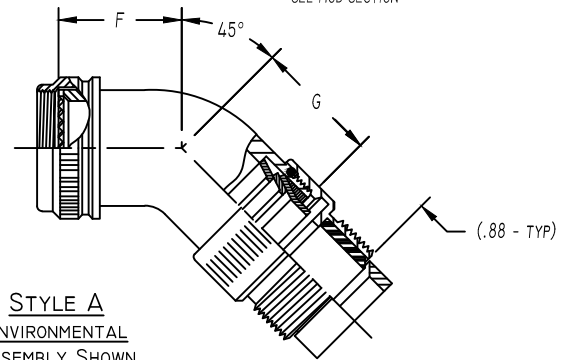
STYLE S



STYLE B



STYLE R
 NON-ENVIRONMENTAL
 ASSEMBLY SHOWN



STYLE A
 ENVIRONMENTAL
 ASSEMBLY SHOWN

ASSEMBLY PART NUMBER

TO ESTABLISH YOU P/N, USE THE FOLLOWING EXAMPLE

E 41 21 S 23 08 9 B 06 51

FUNCTION DESIGNATOR
 E-EMI ADAPTER

CONNECTOR CODE NUMBER - TABLE 1

SERIES PART NUMBER

ADAPTER STYLE
 S = STRAIGHT SPIN COUPLING ADAPTER
 B = STRAIGHT BASIC ADAPTER
 R = 90° ADAPTER
 A = 45° ADAPTER

ACCESSORY ORDER NUMBER-TABLE 1

CABLE ENTRY ORDER NUMBER-TABLE 2

MOD CODE

PLATING CODE NUMBER-TABLE 4

LENGTH CODE NUMBER
 LENGTHS ARE CHOSEN IN 1/4" INCREMENTS
 (IE 08=2.00") SEE TABLE 3 FOR MINIMUM
 INSERT 00 FOR R & A STYLE ADAPTERS

GLAND & O'RING MATERIAL OPTION
 B - NEOPRENE & BUNA-N
 S - SILICONE
 N - NONE REQUIRED (NON ENVIROMENTAL)

CABLE STRAIN RELIEF - SEE TABLE V

Table 1 - Order Number Data

Accessory Order Number By Connector Code & Shell Size

| ORDER NUMBER | Accessory Order Number By Connector Code & Shell Size | | | | | | | | | | A UNIFIED THREAD | B MAX DIA. | C MAX DIA. | D ±.125 DIM. | E MAX DIM. | F ±.125 DIM. | G MAX DIM. | ORDER NUMBER |
|--------------|---|----|---------|---------|---------------|----|----|-------|----|----|------------------------|------------------|------------------|--------------------|------------------|--------------------|------------------|--------------|
| | 18 ④ | 21 | 32 ② | 40 ③ | 41 | 54 | 64 | 61 | 76 | ⑦ | | | | | | | | |
| 01 | 8S (B) | | | | | | | | | | .375-32 | .750 | .531 | | | | | 01 |
| 03 | 8S (A) | | | | | | | | | | .438-27 | .812 | .594 | | | | | 03 |
| 04 | 8S (C) | 8 | | | 8, 9 | | | | | 8 | .438-28 | .812 | .594 | 1.125 | 1.188 | .812 | .875 | 04 |
| 05 | | | | | 8 & 8S | | | | | | .500-20 | .875 | .656 | | | | | 05 |
| 06 | 10S (-) | | | | | | | 8, A | | | .500-28 | .875 | .656 | | | | | 06 |
| 07 | | | | 9, A | | | | | | | M12 x 1.0 | .719 | .656 | | | | | 07 |
| 08 | 10SL (C) | 10 | | | 10, 11 | | 3 | | | 10 | .562-24 | .844 | .719 | | | | | 08 |
| 10 | 10SL(A,B), 12, 12S(B,C) | | | | 10, 10S, 10SL | | 12 | | | | .625-24 | 1.000 | .781 | 1.250 | 1.312 | .875 | .938 | 10 |
| 11 | | | | | | | | 10, B | | | .625-28 | 1.000 | .781 | | | | | 11 |
| 12 | | | | 11, B | | | | | | | M15 x 1.0 | .844 | .781 | | | | | 12 |
| 13 | 12 & 12S (A) | 12 | | 12, 13 | | | | 12 | | | .688-24 | 1.062 | .844 | | | | | 13 |
| 15 | 14 & 14S (-) | | 12 | | 12 & 12S | 7 | 14 | | | | .750-20 | 1.125 | .906 | 1.375 | 1.438 | .938 | 1.000 | 15 |
| 16 | | | | 13, C | | | | | | | M18 x 1.0 | .969 | .906 | | | | | 16 |
| 18 | | 14 | | 14, 15 | | | | | | 14 | .812-20 | 1.188 | .969 | | | | | 18 |
| 19 | 16 & 16S (-) | | 14 | | 14 & 14S | 12 | 16 | | | | .875-20 | 1.250 | 1.031 | 1.500 | 1.562 | 1.000 | 1.062 | 19 |
| 20 | | | | | | | | 14, D | | | .875-28 | 1.250 | 1.031 | | | | | 20 |
| 21 | | | | 15, D | | | | | | | M22 x 1.0 | 1.094 | 1.031 | | | | | 21 |
| 23 | | 16 | | 16, 17 | | | | 16 | | | .938-20 | 1.312 | 1.094 | | | | | 23 |
| 24 | 18 (-) | | 16 | | 16 & 16S | 19 | 18 | | | | 1.000-20 | 1.375 | 1.156 | 1.625 | 1.688 | 1.062 | 1.125 | 24 |
| 25 | | | | | | | | 16, E | | | 1.000-28 | 1.375 | 1.156 | | | | | 25 |
| 26 | | | | 17, E | | | | | | | M25 x 1.0 | 1.219 | 1.156 | | | | | 26 |
| 28 | | 18 | | 18, 19 | 18 | 27 | | 18 | | | 1.062-18 | 1.438 | 1.219 | | | | | 28 |
| 29 | 20 (-) | | 18 | | | | | 20 | | | 1.125-18 | 1.500 | 1.281 | | | | | 29 |
| 30 | 20 (R) | | | | | | | | | | 1.125-24 | 1.500 | 1.281 | 1.750 | 1.812 | 1.094 | 1.156 | 30 |
| 31 | | | | | | | | 18, F | | | 1.125-28 | 1.500 | 1.281 | | | | | 31 |
| 32 | | | | 19, F | | | | | | | M28 x 1.0 | 1.344 | 1.281 | | | | | 32 |
| 34 | | 20 | | 20, 21 | 20 | 37 | | 20 | | | 1.188-18 | 1.562 | 1.344 | | | | | 34 |
| 35 | 22 (-) | | 20 | | | | | 22 | | | 1.250-18 | 1.625 | 1.406 | 1.875 | 1.938 | 1.156 | 1.219 | 35 |
| 36 | | | | | | | | 20, G | | | 1.250-28 | 1.625 | 1.406 | | | | | 36 |
| 37 | | | | 21, G | | | | | | | M31 x 1.0 | 1.469 | 1.406 | | | | | 37 |
| 39 | | 22 | | 22, 23 | 22 | | | 22 | | | 1.312-18 | 1.688 | 1.469 | | | | | 39 |
| 40 | 24 (-) | | 22 | | | | | 24 | | | 1.375-18 | 1.750 | 1.531 | 2.000 | 2.062 | 1.188 | 1.250 | 40 |
| 41 | | | | | | | | 22, H | | | 1.375-28 | 1.750 | 1.531 | | | | | 41 |
| 42 | | | | 23, H | | | | | | | M34 x 1.0 | 1.594 | 1.531 | | | | | 42 |
| 44 | | 24 | | 24, 25 | 24 | | | 24 | | | 1.438-18 | 1.812 | 1.594 | | | | | 44 |
| 45 | | | | | | 61 | | | | | 1.500-18 | 1.875 | 1.656 | | | | | 45 |
| 46 | | | | | | | | 24, J | | | 1.500-28 | 1.875 | 1.656 | 2.125 | 2.188 | 1.250 | 1.312 | 46 |
| 47 | | | | 25, J | | | | | | | M37 x 1.0 | 1.719 | 1.656 | | | | | 47 |
| 48 | | | | | | | | | | | 1.562-18 | 1.938 | 1.719 | | | | | 48 |
| 49 | 28 (-) | | 24 | | | | | 28 | | | 1.625-18 | 2.000 | 1.781 | 2.375 | 2.625 | 1.344 | 1.625 | 49 |
| 51 | | | | | 28 | | | | | | 1.750-18 | 2.125 | 1.906 | | | | | 51 |
| 52 | 32 (B,C) | | 28 | | | | | 32 | | | 1.875-16 | 2.250 | 2.031 | | | | | 52 |
| 53 | 32 (A,R) | | | | | | | | | | 1.906-18 | 2.281 | 2.062 | 2.625 | 3.000 | 1.438 | 1.812 | 53 |
| 54 | | | | | 32 | | | | | | 2.000-18 | 2.375 | 2.156 | | | | | 54 |
| 55 | 36 (B) | | 32 | | | | | 36 | | | 2.062-16 | 2.469 | 2.219 | | | | | 55 |
| 56 | 36 (R) | | | | | | | | | | 2.062-24 | 2.469 | 2.219 | | | | | 56 |
| 57 | 36 (C) | | | | | | | | | | 2.125-16 | 2.500 | 2.281 | 2.875 | 3.250 | 1.562 | 1.938 | 57 |
| 58 | 36 (A) | | | | | | | | | | 2.125-18 | 2.500 | 2.281 | | | | | 58 |
| 59 | | | | | 36 | | | | | | 2.250-16 | 2.625 | 2.406 | | | | | 59 |
| 60 | 40 (B) | | 36 | | | | | 40 | | | 2.312-16 | 2.719 | 2.469 | | | | | 60 |
| 61 | 40 (A,C) | | | | | | | | | | 2.375-16 | 2.750 | 2.531 | 3.125 | 3.500 | 1.688 | 2.062 | 61 |
| 62 | | | | | 40 | | | | | | 2.500-16 | 2.875 | 2.656 | | | | | 62 |

NOTES: UNLESS OTHERWISE SPECIFIED.

1 THREADS ARE RIGHT HAND IN ACCORDANCE WITH FED-STD-H28, CLASS 2B.

② THREADS NOTED ARE LEFT HAND, CLASS 2B.

③ THREADS NOTED ARE ISO METRIC, CLASS 6H.

④ CODE 18 SHELL SIZES ARE FOLLOWED IN PARENTHESIS BY CONNECTOR MFR CODE. SEE CONNECTOR CODE 18 CHART AT RIGHT & EXAMPLE PART NUMBER FOR DETAILS.

5 TABLE 1 LISTS THE MOST USED CONNECTOR CODES. SEE SECTION 11 FOR OTHER CODES AVAILABLE AND COMPLETE CONNECTOR PART NUMBER CROSS REFERENCE.

⑥ SEE SUPPORT DATA SECTION FOR PLATING AND MODIFICATION CODE OPTIONS.

⑦ ADD .25 TO "D" & "F" FOR CONNECTOR CODES 30, 32 & 61.

⑧ SEE SUPPORT DATA SECTION FOR TABLE V & AVAILABLE STYLES

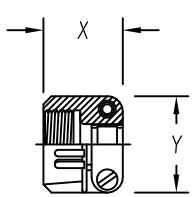
④ Connector Code 18 Chart

| CONNECTOR CODE | CONNECTOR MANUFACTURER (MS3100, MS3101, MS3106 & MS3107) |
|----------------|--|
| A | AMPHENOL, CLASS A |
| B | BENDIX, CLASS A, E & R |
| C | CANNON, CLASS A, E & R |
| D | MFR. UNKNOWN, CLASS A, E & R |
| R | AMPHENOL, CLASS R |
| - | MFR. CODE NOT REQUIRED |

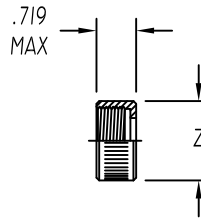


Table 2 - Environmental / Non-Environmental Cable Entry Data

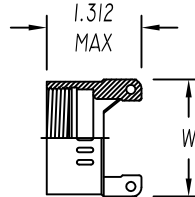
| ENTRY ORDER NUMBER | ENVIRONMENTAL | | NON ENVIRONMENTAL | | V UNIFIED THREAD | R MAX DIM. | S MAX DIM. | T MAX DIM. | U MAX DIM. | W MAX DIM. | X MAX DIM. | Y MAX DIM. | Z MAX DIA. |
|--------------------------|---------------|-------|-------------------|-------|------------------------|------------------|------------------|------------------|------------------|------------------|------------------|------------------|------------------|
| | GLAND RANGE | | CABLE RANGE | | | | | | | | | | |
| | MAX | MIN | MAX | MIN | | | | | | | | | |
| △ 03 | .250 | .156 | .250 | .156 | .500-28 | N / A | .812 | 1.375 | .812 | N / A | .844 | .781 | .656 |
| 04 | .312 | .188 | .312 | .188 | .625-24 | 1.031 | .937 | 1.375 | .937 | .875 | .844 | .906 | .781 |
| 06 | .438 | .281 | .438 | .281 | .750-20 | 1.031 | 1.062 | 1.375 | 1.062 | 1.000 | .906 | 1.094 | .906 |
| 08 | .562 | .375 | .562 | .344 | .875-20 | 1.031 | 1.188 | 1.375 | 1.188 | 1.125 | .969 | 1.188 | 1.031 |
| 10 | .625 | .500 | .625 | .375 | 1.000-20 | 1.094 | 1.312 | 1.437 | 1.312 | 1.250 | .969 | 1.281 | 1.156 |
| 12 | .750 | .500 | .750 | .438 | 1.188-18 | 1.219 | 1.562 | 1.437 | 1.562 | 1.375 | .969 | 1.500 | 1.344 |
| △ 14 | .875 | .750 | .875 | .719 | 1.250-18 | N / A | N / A | N / A | N / A | 1.500 | N / A | N / A | N / A |
| 16 | 1.000 | .844 | 1.000 | .781 | 1.438-18 | 1.219 | 1.750 | 1.562 | 1.750 | 1.625 | 1.062 | 1.719 | 1.594 |
| 20 | 1.250 | .938 | 1.250 | .750 | 1.750-18 | 1.344 | 2.250 | 1.812 | 2.250 | 1.750 | 1.125 | 2.062 | 1.906 |
| 24 | 1.375 | 1.000 | 1.375 | .781 | 2.000-18 | N / A | 2.375 | 2.062 | 2.375 | N / A | 1.188 | 2.312 | 2.156 |
| 28 | 1.625 | 1.250 | 1.625 | .969 | 2.250-16 | N / A | 2.625 | 2.062 | 2.625 | N / A | 1.719 | 2.719 | 2.406 |
| 32 | 1.875 | 1.500 | 1.875 | 1.125 | 2.500-16 | N / A | 2.812 | 2.188 | 2.812 | N / A | 1.781 | 2.969 | 2.656 |



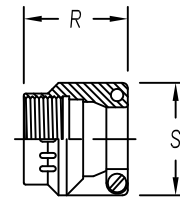
STYLE 1 △
 AS85049/41A CLAMP
 (MS 3057**A)



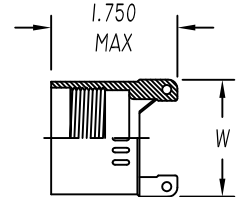
STYLE 2 △
 NUT



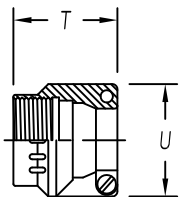
STYLE 3 △
 NON-ENVIRONMENTAL



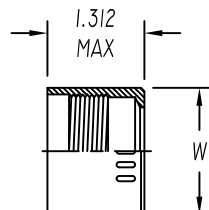
STYLE 3 △
 NUT
 ENVIRONMENTAL
 (AS85049/1)
 (MS 3057-**B)



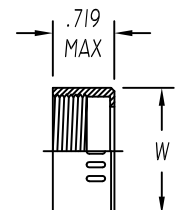
STYLE 3 △
 ENVIRONMENTAL



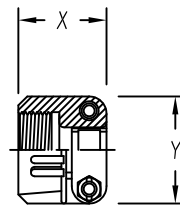
STYLE 4 △
 STRAIN RELIEF
 ENVIRONMENTAL
 (AS85049/2)
 (MS 3057-**C)



STYLE 4 △
 ENVIRONMENTAL



STYLE 4 △
 NON-ENVIRONMENTAL



STYLE 9 △
 STRAIN-RELIEF CLAMP
 WITH TELESCOPING SCREWS

NOTES: UNLESS OTHERWISE SPECIFIED

△1 AVAILABLE ONLY ON: A**01, A**30, E**01, E**03, E**04, E**05, E**07, E**21, E**30, & E**33

△2 AVAILABLE ONLY ON: E**15, E**17, E**38, E**40, & E**41

3. CONSULT FACTORY FOR SIZES AND INFORMATION NOT LISTED