



**ELECTRO ADAPTER INC.**  
 CHATSWORTH, CALIFORNIA, USA 91311  
 PHONE (818) 998-1198  
 FAX (818) 709-5773

**RECTANGULAR BACKSHELL  
 BAND TERMINATION,  
 STRAIGHT, 45°, 90° FRONT ENTRY  
 MIL - DTL - 83513, /1, /2, /3, & /4, MICRO D**

**901-748**

SHEET 1 OF 1

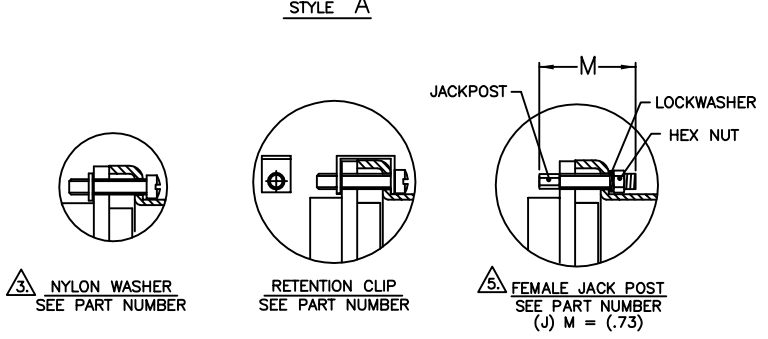
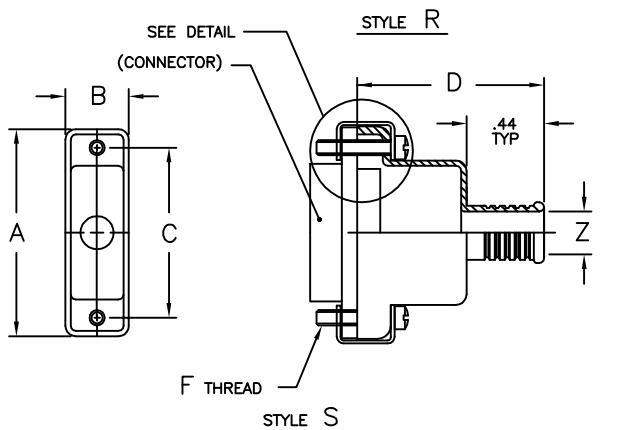
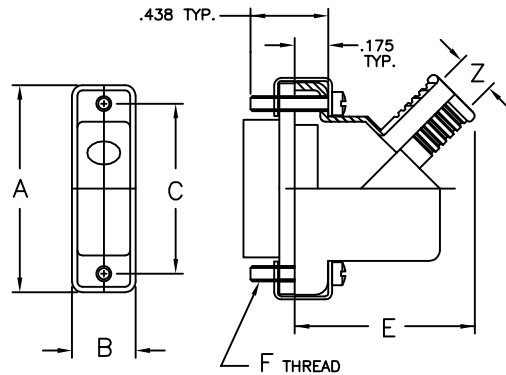
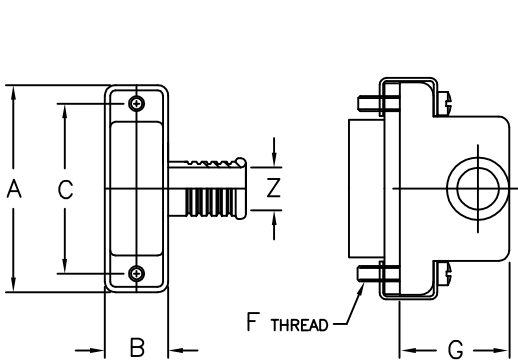

*Example Part Number*

901-748S1505121\*C

BASIC ADAPTER NO.

ADAPTER STYLE  
 S = STRAIGHT ADAPTER  
 A = 45° ADAPTER  
 R = 90° ADAPTER

ADD 'C' FOR ADAPTER SUPPLIED WITH SCREW RETENTION CLIPS, OMIT IF NOT REQUIRED.

SHELL SIZE	CONNECTOR ORDER NUMBER							
	A	B	C	D	E	F	G	MAX ENTRY SIZE
0 9	.775	.360	.565	.750	1.00	2-56UNC-2A	.607	0 5
1 5	.925	.360	.715	.880	1.26	2-56UNC-2A	.643	0 5
2 1	1.075	.360	.865	1.000	1.05	2-56UNC-2A	.677	0 5
2 5	1.175	.360	.965	1.060	1.23	2-56UNC-2A	.718	0 5
3 1	1.325	.360	1.115	1.120	1.13	2-56UNC-2A	.726	0 6
3 7	1.475	.360	1.265	1.160	1.16	2-56UNC-2A	.744	0 8
5 1	1.425	.400	1.215	1.190	1.25	2-56UNC-2A	.828	0 8
1 0 0	2.160	.450	1.800	1.250	1.32	4-40UNC-2A	.948	0 9

CABLE ENTRY ORDER NUMBER	
ENTRY NUMBER	ØZ ±.010
0 1	.125
0 2	.156
0 3	.188
0 4	.219
0 5	.250
0 6	.281
0 7	.312
0 8	.344
0 9	.375

PLATING CODE NUMBER  
 CODE 21 - IRIDIUM, NO. 14-2 PER MIL-C-5541 CLASS 3  
 CODE 54 - CADMIUM, GOLD, PER QQ-P-416, TYPE II, CLASS 3, OVER ELECTROLESS NICKEL PER MIL-C-26074 CLASS 3 OR 4, GRADE B. (.0005 MIN)  
 CODE 55 - CADMIUM, OLIVE DRAB, PER QQ-P-416, TYPE II, CLASS 3, OVER ELECTROLESS NICKEL PER MIL-C-26074 CLASS 3 OR 4, GRADE B. (.0005 MIN) (1000 HOUR SALT SPRAY)  
 CODE 56 - ELECTROLESS NICKEL, PER MIL-C-26074, CLASS 4, GRADE A.  
 FOR ADDITIONAL FINISH OPTIONS, SEE CATALOG TABLE 4.

JACKSCREW TYPE  
 F = 2 MALE FILLISTER (ANS5002-7)  
 H = MALE HEX SOCKET (NAS1352C0\*-7)  
 J = FEMALE JACKPOST (10-000-0050)  
 OMIT IF NO REQUIRED

1 = ADAPTER ONLY  
 2 = ADAPTER WITH 214L0002 BAND  
 8 = ADAPTER WITH 214L0005 BAND

NOTES: UNLESS OTHERWISE SPECIFIED.

- ASSEMBLY IDENTIFICATION PER MIL-STD-1285.
- MATERIAL: ADAPTER - ALUMINUM ALLOY.  
HARDWARE - SST
- SCREWS ARE CAPTIVATED WITH NYLON WASHERS STANDARD, NOT SUPPLIED WITH 'C' OPTION.
- CONSULT FACTORY FOR ADAPTERS THAT MATE WITH /6, /7, /8 & /9, CLASS P (PLASTIC SHELL CONNECTOR).
- JACK POST SUPPLIED WITH 2 LOCK WASHER AND 2 HEX NUT. (CONSULT FACTORY FOR SHELL SIZE 100)