

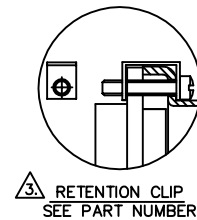

ELECTRO ADAPTER INC.
 CHATSWORTH, CALIFORNIA, USA 91311
 PHONE (818) 998-1198
 FAX (818) 709-5773

RECTANGULAR BACKSHELL, EMI/RFI ⁴
MAGNEFORMED SHIELD TERMINATION
STRAIGHT, 45°, & 90° FRONT ENTRY
MIL - DTL - 83513, /1, /2, /3, & /4, MICRO D

901-726
 SHEET 1 OF 1

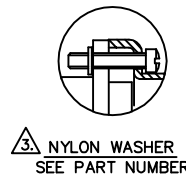
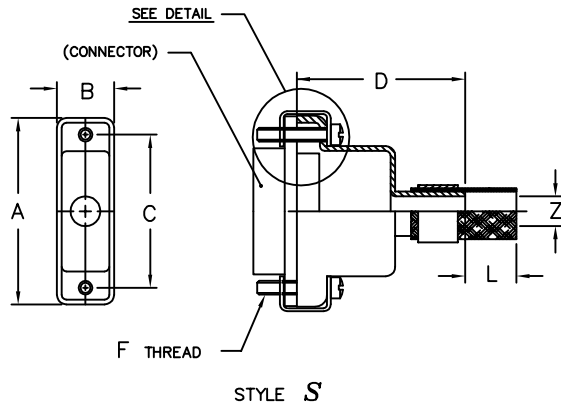
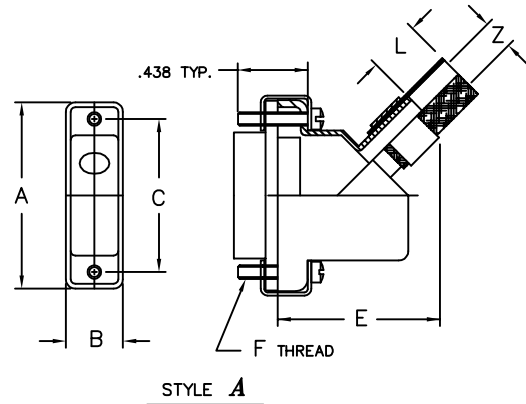
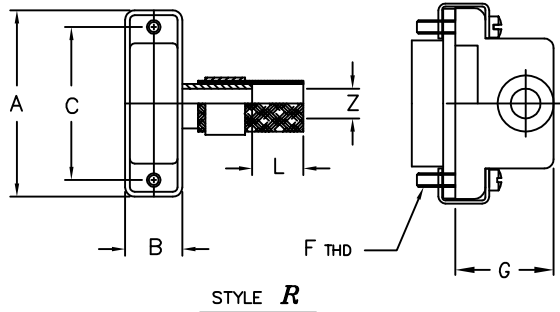

Example Part Number
901-726S25030655*C

BASIC ADAPTER NO.

ADAPTER STYLE
 S - STRAIGHT ADAPTER
 A - 45° ADAPTER
 R - 90° ADAPTER

PLATING CODE NUMBER
 CODE 55 - CADMIUM PER QQ-P-416, TYPE II, CLASS 3, OVER ELECTROLESS NICKEL PER MIL-C-26074 CLASS 3 OR 4, GRADE B.
 CODE 56 - ELECTROLESS NICKEL, PER MIL-C-26074, CLASS 4, GRADE A. FOR ADDITIONAL FINISH OPTIONS, SEE CATALOG TABLE 4.

JACKSCREW TYPE
 F = 2 MALE FILLISTER
 H = 2 MALE HEX SOCKET
 J = 2 FEMALE JACKPOST
 OMIT IF JACKSCREWS NOT REQUIRED

CONNECTOR ORDER NUMBER								
SHELL SIZE	A	B	C	D	E	F	G	MAX ENTRY
	±.010	±.010	±.010	±.020	MAX	UNIFIED THD	±.031	
0 9	.775	.360	.565	.750	1.00	2-56UNC-2A	.607	05
1 5	.925	.360	.715	.880	1.03	2-56UNC-2A	.634	05
2 1	1.075	.360	.865	1.000	1.05	2-56UNC-2A	.677	05
2 5	1.175	.360	.965	1.060	1.09	2-56UNC-2A	.718	05
3 1	1.325	.360	1.115	1.120	1.13	2-56UNC-2A	.726	05
3 7	1.475	.360	1.265	1.160	1.16	2-56UNC-2A	.744	05
5 1	1.425	.400	1.215	1.190	1.25	2-56UNC-2A	.828	07
1 0 0	2.160	.450	1.800	1.250	1.32	4-40UNC-2A	.948	09

CABLE ENTRY ORDER NUMBER	
ENTRY NUMBER	ØZ
	±.010
0 1	.125
0 2	.156
0 3	.188
0 4	.219
0 5	.250
0 6	.281
0 7	.312
0 8	.344
0 9	.375

LENGTH CODE "L"
 LENGTH IN 1 INCH INCREMENTS
 6 INCH MINIMUM ORDER LENGTH
 00 - IF SHIELD NOT REQUIRED

NOTES: UNLESS OTHERWISE SPECIFIED.

1. ASSEMBLY IDENTIFICATION PER MIL-STD-1285.

2. MATERIAL: ADAPTER - ALUMINUM ALLOY.
 HARDWARE - SST.
 BRAID - TINNED COPPER.

³ SCREWS CAPTIVATED WITH NYLON WASHERS STANDARD, NOT SUPPLIED WITH 'C' OPTION.

⁴ CONSULT FACTORY FOR ADAPTERS THAT MATE WITH /6, /7, /8 & /9 CLASS P (PLASTIC SHELL CONNECTORS).

REV | K