

| | | | |
|--------------|---------|-----------------|---------------|
| PART NO. | | | |
| 100-38999/32 | | | |
| REVISIONS | | | |
| LTR | ECO NO. | DRAWN | APPR. |
| A | 22202 | PADM 2/11/13 | GF 2/11/13 |

Example Part Number
100-38999/32W15N

BASIC ADAPTER NO.

PLATING CODE NUMBER

- F - ELECTROLESS NICKEL, PER MIL-C-26074, CLASS 3 OR 4, GRADE B.
- W - CADMIUM, OLIVE DRAB PER QQ-P-416, TYPE II, CLASS 3, OVER ELECTROLESS NICKEL PER MIL-C-26074 CLASS 3 OR 4, GRADE B.
- Z - ZINC NICKEL, BLACK PER ASTM-B841, GRADE 10, TYPE D, CLASS 1, OVER ELECTROLESS NICKEL, GRADE B, CLASS 4.

CONNECTOR ORDER NUMBER

| ORDER NUMBER | SHELL SIZE | | A THREAD 0.1P-03L-TS | Ø B MAX | Ø C + .000 - .006 | Ø D MIN. TYPE N ONLY |
|--------------|------------|------|-------------------------|------------|-------------------------|----------------------------|
| | COM'L | MIL. | | | | |
| 9 | 9 | A | .6250 | .906 | .492 | .512 |
| 11 | 11 | B | .7500 | 1.024 | .620 | .709 |
| 13 | 13 | C | .8750 | 1.220 | .769 | .787 |
| 15 | 15 | D | 1.000 | 1.299 | .894 | .906 |
| 17 | 17 | E | 1.1875 | 1.457 | 1.019 | 1.024 |
| 19 | 19 | F | 1.2500 | 1.575 | 1.124 | 1.142 |
| 21 | 21 | G | 1.3750 | 1.732 | 1.249 | 1.260 |
| 23 | 23 | H | 1.5000 | 1.811 | 1.374 | 1.339 |
| 25 | 25 | J | 1.6250 | 1.969 | 1.499 | 1.535 |

STYLE OPTION

- R - NO SOLID RING ATTACHEMENT, SUPPLIED WITH STANDARD WIRE ROPE
- N - SUPPLIED WITH BOTH SOLID RING ATTACHEMENT & STANDARD WIRE ROPE

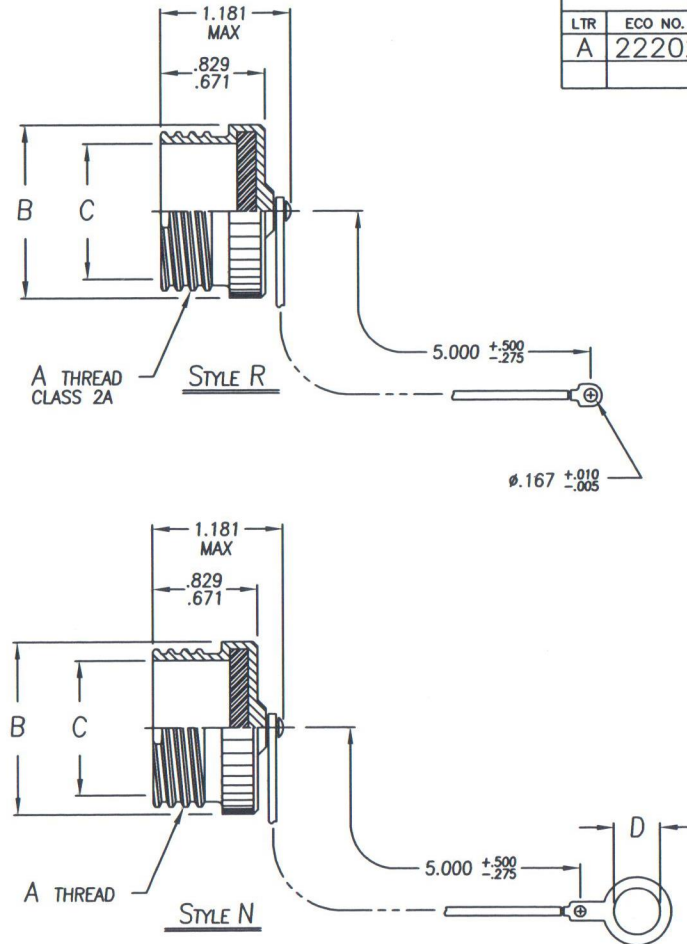

NOTES: UNLESS OTHERWISE SPECIFIED

1. IDENTIFICATION PER MIL-STD-1285
2. MATERIAL: ADAPTER - ALLUMINUM ALLOY
 HARDWARE - STAINLESS STEEL - PASSIVATED
 GASKET - SILICONE
3. FINISH: SEE EXAMPLE PART NUMBER

The information disclosed herein is the property of, and a proprietary item originated by ELECTRO ADAPTER, INC., who reserves all patent, proprietary design, use, sale, manufacturing and reproduction rights thereto; except for uses expressly granted to the United States Government and items which are vendor parts, disclosure shall not be made without written consent from ELECTRO ADAPTER, INC.

UNLESS OTHERWISE SPECIFIED
 DIMENSIONS ARE IN INCHES
 TOLERANCES: ANGLES DECIMALS
 ± 2° .XX = ± .06
 .XXX = ± .031
 DO NOT SCALE DRAWING

| | |
|----------|----------|
| DRAWN | DATE |
| SJDC | 11/01/12 |
| CHKD | DATE |
| GF | 11/01/12 |
| APVD | DATE |
| GF | 11/01/12 |
| GF | 11/01/12 |
| RELEASED | DATE |

| | | | |
|--|-----------|-----------------------|--------------|
| ELECTRO ADAPTER, INC. CHATSWORTH, CA. 91311-6189 | | | |
| DRAWING TITLE | | | |
| DUST CAP FOR MIL-DTL-38999, SERIES III, CONNECTORS | | | |
| SIZE | CAGE CODE | DRAWING NUMBER | REV. |
| A | 31461 | 100-38999/32 | A |
| SCALE: NONE | | /0/SALES/100/38999/32 | SHEET 1 OF 1 |

Example Part Number
100-38999/33W15N

BASIC ADAPTER NO.

PLATING CODE NUMBER

- F - ELECTROLESS NICKEL, PER MIL-C-26074, CLASS 3 OR 4, GRADE B.
- W - CADMIUM, OLIVE DRAB PER QQ-P-416, TYPE II, CLASS 3, OVER ELECTROLESS NICKEL PER MIL-C-26074 CLASS 3 OR 4, GRADE B.
- Z - ZINC NICKEL, BLACK PER ASTM-B841, GRADE 10, TYPE D, CLASS 1, OVER ELECTROLESS NICKEL, GRADE B, CLASS 4.

CONNECTOR ORDER NUMBER

| ORDER NUMBER | SHELL SIZE | | A THREAD 0.1P-03L-TS | Ø B MAX | Ø C MAX | Ø D MIN. TYPE N ONLY |
|--------------|------------|------|----------------------------|------------|------------|----------------------------|
| | COM'L | MIL. | | | | |
| 9 | 9 | A | .6250 | .91 | 1.06 | .69 |
| 11 | 11 | B | .7500 | 1.10 | 1.26 | .86 |
| 13 | 13 | C | .8750 | 1.20 | 1.46 | .99 |
| 15 | 15 | D | 1.000 | 1.26 | 1.57 | 1.18 |
| 17 | 17 | E | 1.1875 | 1.46 | 1.73 | 1.26 |
| 19 | 19 | F | 1.2500 | 1.54 | 1.81 | 1.43 |
| 21 | 21 | G | 1.3750 | 1.65 | 1.93 | 1.51 |
| 23 | 23 | H | 1.5000 | 1.77 | 2.13 | 1.68 |
| 25 | 25 | J | 1.6250 | 1.93 | 2.20 | 1.75 |

STYLE OPTION

- R - NO SOLID RING ATTACHEMENT, SUPPLIED WITH STANDARD WIRE ROPE
- N - SUPPLIED WITH BOTH SOLID RING ATTACHEMENT & STANDARD WIRE ROPE

NOTES: UNLESS OTHERWISE SPECIFIED

1. IDENTIFICATION PER MIL-STD-1285
2. MATERIAL: ADAPTER - ALLUMINUM ALLOY
 HARDWARE - STAINLESS STEEL - PASSIVATED
 GASKET - SILICONE
3. FINISH: SEE EXAMPLE PART NUMBER

| PART NO. | | | |
|--------------|---------|-----------------|---------------|
| 100-38999/33 | | | |
| REVISIONS | | | |
| LTR | ECO NO. | DRAWN | APPR. |
| A | 22202 | PADM 2/11/13 | GF 2/11/13 |

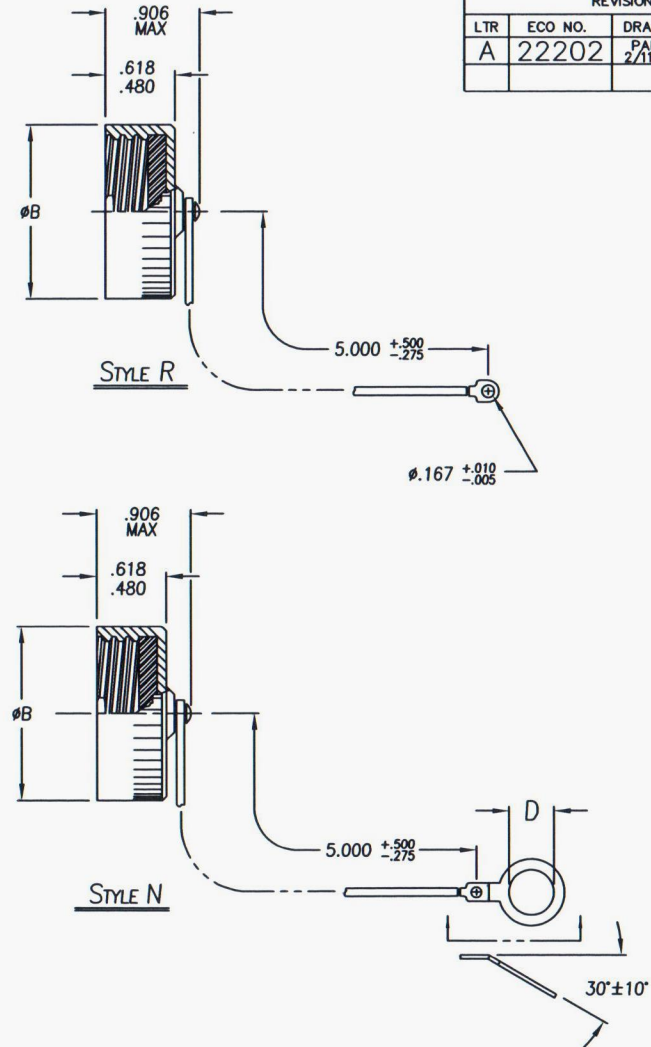

| | | | | | |
|--|---------------|------------------|---|--------------------|--------------------------------|
| The information disclosed herein is the property of, and a proprietary item originated by ELECTRO ADAPTER, INC., who reserves all patent, proprietary design, use, sale, manufacturing and reproduction rights thereto; except for uses expressly granted to the United States Government and items which are vendor parts, disclosure shall not be made without written consent from ELECTRO ADAPTER, INC. UNLESS OTHERWISE SPECIFIED DIMENSIONS ARE IN INCHES TOLERANCES: ANGLES DECIMALS ± 2° .XX = ± .06 .XXX = ± .031 DO NOT SCALE DRAWING | DRAWN SJDC | DATE 11/01/12 | ELECTRO ADAPTER, INC. CHATSWORTH, CA. 91311-6189 DRAWING TITLE DUST CAP FOR MIL-DTL-38999, SERIES III, CONNECTORS | | |
| | CHKD GF | DATE 11/01/12 | | | |
| | APVD GF | DATE 11/01/12 | | | |
| | GF | 11/01/12 | SIZE A | CAGE CODE 31461 | DRAWING NUMBER 100-38999/33 |
| RELEASED | DATE | SCALE: NONE | /0/SALES/100/38999/32 | SHEET 1 OF 1 | |