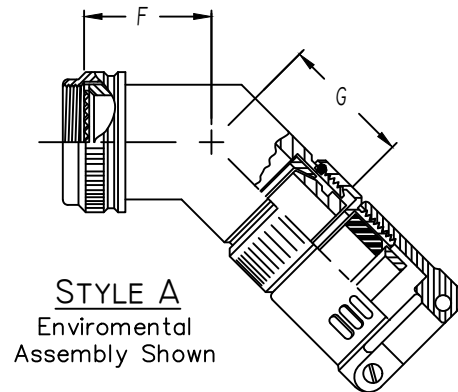
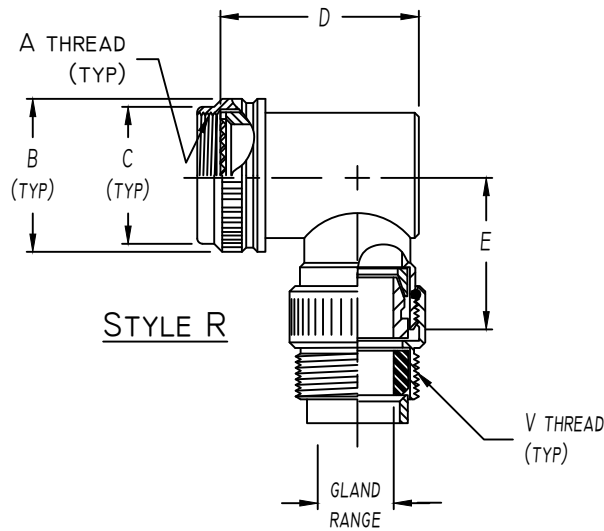




Table 2 - Cable Entry Data

ENTRY ORDER NUMBER	ENVIRONMENTAL GLAND RANGE		NON ENVIRONMENTAL CABLE RANGE		UNIFIED THREAD
	MAX	MIN	MAX	MIN	
03	.250	.156	.250	.156	.500-28
04	.312	.188	.312	.188	.625-24
06	.438	.281	.438	.281	.750-20
08	.562	.375	.562	.344	.875-20
10	.625	.500	.625	.375	1.000-20
12	.750	.500	.750	.438	1.188-18
16	.938	.625	.938	.562	1.438-18
20	1.250	.938	1.250	.750	1.750-18
24	1.375	1.000	1.375	.781	2.000-18
28	1.625	1.250	1.625	.969	2.250-16
32	1.875	1.500	1.875	1.125	2.500-16

WHEN MAXIMUM CABLE ENTRY EXCEEDS THE CONNECTOR INTERFACE DIAMETER, A 2 PIECE ADAPTER WILL BE SUPPLIED.



**OTHER CONNECTOR CODES AVAILABLE
 CONTACT ENGINEERING FOR DETAILS**

ASSEMBLY PART NUMBER

TO ESTABLISH YOUR P/N, USE THE FOLLOWING EXAMPLE

E 41 30 S 23 08 9 B 51

FUNCTION DESIGNATOR
 E-EMI ADAPTER

CONNECTOR CODE NUMBER - TABLE 1 (6)

SERIES PART NUMBER

ADAPTER STYLE
 S = STRAIGHT SPIN COUPLING ADAPTER
 B = STRAIGHT BASIC ADAPTER
 R = 90° ADAPTER
 A = 45° ADAPTER

ACCESSORY ORDER NUMBER-TABLE 1

MOD CODE (6)

PLATING CODE NUMBER-TABLE 4 (6)

GLAND & O'RING MATERIAL OPTION
 B - NEOPRENE & BUNA-N
 S - SILICONE
 N - NONE REQUIRED (NON ENVIROMENTAL)

CABLE STRAIN RELIEF - SEE TABLE V (8)

CABLE ENTRY ORDER NUMBER-TABLE 2

Table 1 - Order Number Data

E * * 30
SHEET 2 OF 2

Accessory Order Number By Connector Code & Shell Size

ORDER NUMBER	MIL-DTL-38999 SERIES III & IV		MIL-DTL-38999 SERIES I & II		MIL-DTL-3015 CRIMP		MIL-DTL-20482 SER 2		MIL-DTL-83723 SER III		MIL-C-81703 NAS 1509		ORDER NUMBER
	40	41	54		A	B	C	D	E	F	G		
	③				UNIFIED THREAD	MAX DIA.	MAX DIA.	REF DIM.	REF DIM.	REF DIM.	REF DIM.		
01					.375-32	.750	.531	1.031		.500			01
03					.438-27	.812	.594	1.094		.500			03
04		8, 9			.438-28	.812	.594	1.000	1.188	.750			04
05			8 & 8S		.500-20	.875	.656	.938		.719	1.062		05
06					.500-28	.875	.656	1.562		1.062			06
07	9, A				M12 x 1.0	.719	.656	.938	1.250	.500			07
08		10, 11		3	.562-24	.844	.719	1.375		.750			08
10			10,10S,10SL		.625-24	1.000	.781	1.562		1.062			10
11					.625-28	1.000	.781	1.688		1.062	1.094		11
12	11, B				M15 x 1.0	.844	.781	1.125	1.312	.500			12
13		12, 13			.688-24	1.062	.844	1.500		.750			13
15			12 & 12S	7	.750-20	1.125	.906	1.812		.875			15
16	13, C				M18 x 1.0	.969	.906	1.188	1.375	.562	1.125		16
18		14, 15			.812-20	1.188	.969	1.500		.812			18
19			14 & 14S	12	.875-20	1.250	1.031	1.875		.750			19
20					.875-28	1.250	1.031	1.938		1.125			20
21	15, D				M22 x 1.0	1.094	1.031	1.312	1.438	.562			21
23		16, 17			.938-20	1.312	1.094	1.625		.875			23
24			16 & 16S	19	1.000-20	1.375	1.156	2.000		.719			24
25					1.000-28	1.375	1.156	2.062	1.500	1.156			25
26	17, E				M25 x 1.0	1.219	1.156	1.438		.594	1.188		26
28		18, 19	18	27	1.062-18	1.438	1.219	1.688		.875			28
29					1.125-18	1.500	1.281	2.156		.938			29
30					1.125-24	1.500	1.281	1.938	1.562	.625			30
31					1.125-28	1.500	1.281	2.125		1.188			31
32	19, F				M28 x 1.0	1.344	1.281	1.500		.625			32
34		20, 21	20	37	1.188-18	1.562	1.344	1.812		.875			34
35					1.250-18	1.625	1.406	2.250		.938			35
36					1.250-28	1.625	1.406	2.250	1.625	1.250	1.219		36
37	21, G				M31 x 1.0	1.469	1.406	1.625		.688			37
39		22, 23	22		1.312-18	1.688	1.469	1.938		.938			39
40					1.375-18	1.750	1.531	2.375		1.000			40
41					1.375-28	1.750	1.531	2.375		1.250			41
42	23, H				M34 x 1.0	1.594	1.531	1.750		.656	1.250		42
44		24, 25	24		1.438-18	1.812	1.594	2.000		1.000			44
45				61	1.500-18	1.875	1.656	1.875	1.688	.938	1.438		45
46					1.500-28	1.875	1.656	2.500		1.250			46
47	25, J				M37 x 1.0	1.719	1.656	1.875		.688	1.250		47
48					1.562-18	1.938	1.719	2.125		1.062			48
49					1.625-18	2.000	1.781	2.500	1.812	1.250	1.312		49
51			28		1.750-18	2.125	1.906	2.062		.938			51
52					1.875-16	2.250	2.031	2.750	1.938	1.125	1.344		52
53					1.906-18	2.281	2.062	2.438		.750			53
54			32		2.000-18	2.375	2.156	2.312		.969			54
55					2.062-16	2.469	2.219	3.000		.969			55
56					2.062-24	2.469	2.219	1.875	2.062	.812	1.406		56
57					2.125-16	2.500	2.281	1.875		.812			57
58					2.125-18	2.500	2.281	1.875		.812			58
59			36		2.250-16	2.625	2.406	2.438		1.031			59
60					2.312-16	2.719	2.469	3.250	2.188	1.000	1.438		60
61					2.375-16	2.750	2.531	2.000		.875			61
62			40		2.500-16	2.875	2.656	2.688	2.750	1.125	1.500		62

NOTES: UNLESS OTHERWISE SPECIFIED.

1 THREADS ARE RIGHT HAND IN ACCORDANCE WITH FED-STD-H28, CLASS 2B.

5

TABLE 1 LISTS THE MOST USED CONNECTOR CODES. SEE SECTION 11 FOR OTHER CODES AVAILABLE AND COMPLETE CONNECTOR PART NUMBER CROSS REFERENCE.

⑥ SEE SUPPORT DATA SECTION FOR PLATING AND MODIFICATION CODE OPTIONS.

③ THREADS NOTED ARE ISO METRIC, CLASS 6H.

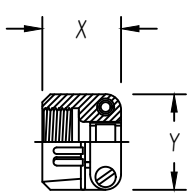
⑧ SEE SUPPORT DATA SECTION FOR TABLE V & AVAILABLE STYLES

REV C

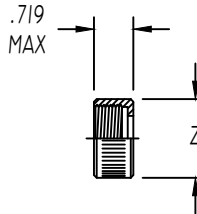


Table 2 - Environmental / Non-Environmental Cable Entry Data

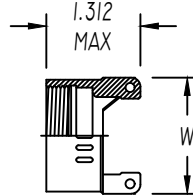
ENTRY ORDER NUMBER	ENVIRONMENTAL		NON ENVIRONMENTAL		V UNIFIED THREAD	R MAX DIM.	S MAX DIM.	T MAX DIM.	U MAX DIM.	W MAX DIM.	X MAX DIM.	Y MAX DIM.	Z MAX DIA.
	GLAND	RANGE	CABLE	RANGE									
	MAX	MIN	MAX	MIN									
△ 03	.250	.156	.250	.156	.500-28	N / A	.812	1.375	.812	N / A	.844	.781	.656
04	.312	.188	.312	.188	.625-24	1.031	.937	1.375	.937	.875	.844	.906	.781
06	.438	.281	.438	.281	.750-20	1.031	1.062	1.375	1.062	1.000	.906	1.094	.906
08	.562	.375	.562	.344	.875-20	1.031	1.188	1.375	1.188	1.125	.969	1.188	1.031
10	.625	.500	.625	.375	1.000-20	1.094	1.312	1.437	1.312	1.250	.969	1.281	1.156
12	.750	.500	.750	.438	1.188-18	1.219	1.562	1.437	1.562	1.375	.969	1.500	1.344
△ 14	.875	.750	.875	.719	1.250-18	N / A	N / A	N / A	N / A	1.500	N / A	N / A	N / A
16	1.000	.844	1.000	.781	1.438-18	1.219	1.750	1.562	1.750	1.625	1.062	1.719	1.594
20	1.250	.938	1.250	.750	1.750-18	1.344	2.250	1.812	2.250	1.750	1.125	2.062	1.906
24	1.375	1.000	1.375	.781	2.000-18	N / A	2.375	2.062	2.375	N / A	1.188	2.312	2.156
28	1.625	1.250	1.625	.969	2.250-16	N / A	2.625	2.062	2.625	N / A	1.719	2.719	2.406
32	1.875	1.500	1.875	1.125	2.500-16	N / A	2.812	2.188	2.812	N / A	1.781	2.969	2.656



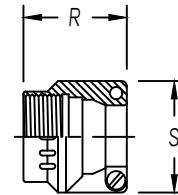
STYLE 1 △
 AS85049/41A CLAMP
 (MS 3057**A)



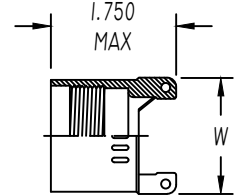
STYLE 2 △
 NUT



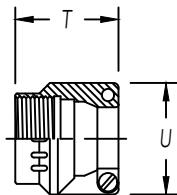
STYLE 3 △
 NON-ENVIRONMENTAL



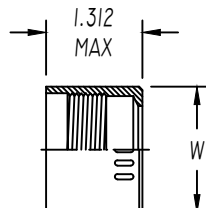
STYLE 3 △
 NUT ENVIRONMENTAL
 (AS85049/1)
 (MS 3057-**B)



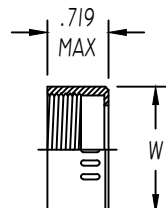
STYLE 3 △
 ENVIRONMENTAL



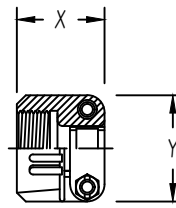
STYLE 4 △
 STRAIN RELIEF ENVIRONMENTAL
 (AS85049/2)
 (MS 3057-**C)



STYLE 4 △
 ENVIRONMENTAL



STYLE 4 △
 NON-ENVIRONMENTAL



STYLE 9 △
 STRAIN-RELIEF CLAMP WITH TELESCOPING SCREWS

NOTES: UNLESS OTHERWISE SPECIFIED

△ AVAILABLE ONLY ON: A**01, A**30, E**01, E**03, E**04, E**05, E**07, E**21, E**30, & E**33

△ AVAILABLE ONLY ON: E**15, E**17, E**38, E**40, & E**41

3. CONSULT FACTORY FOR SIZES AND INFORMATION NOT LISTED