



ELECTRO ADAPTER INC.
 CHATSWORTH, CALIFORNIA, USA 91311
 PHONE (818) 998-1198
 FAX (818) 709-5773

**SECTION 1 - MECHANICAL
 STRIN RELIEF, EMI / RFI, EMP,
 SINGLE CONE, SPLIT SHELL, LOW PROFILE
 SAE AS85049 CATEGORY 1**

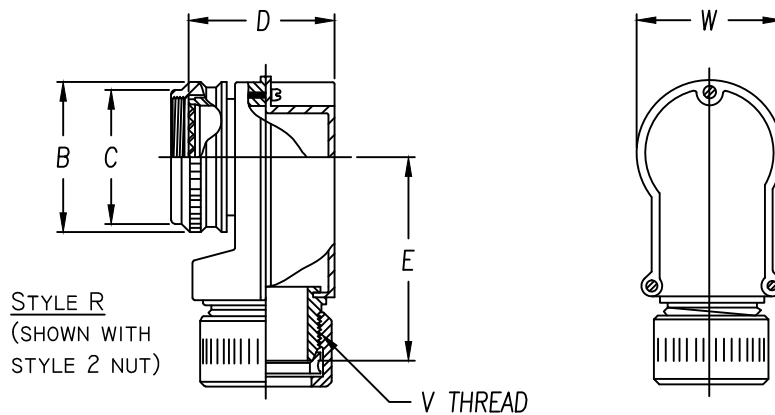
E * * 41

SHEET 1 OF 2

Table 2 - Cable Entry Data

ENTRY ORDER NUMBER	CABLE RANGE		V	W
	MAX	MIN	UNIFIED THD CLASS 2A	REF
04	.250	.125	.625 - 24	.844
06	.375	.219	.750 - 20	.984
08	.500	.344	.875 - 20	1.125
10	.625	.469	1.000 - 20	1.344
12	.750	.594	1.125 - 18	1.344
14	.875	.719	1.250 - 18	1.469

AVAILABLE FOR CONNECTOR CODES 40, 41, 47 & 54. CONSULT FACTORY FOR TABLE 1 DIMENSIONS ON OTHER CODES.



ASSEMBLY PART NUMBER

TO ESTABLISH YOU P/N, USE THE FOLLOWING EXAMPLE

E 41 41 R 23 08 9 51

FUNCTION DESIGNATOR
E - EMI ADAPTER

CONNECTOR CODE NUMBER - TABLE 1 (6)

SERIES PART NUMBER

ADAPTER STYLE
R = 90° ADAPTER

ACCESSORY ORDER NUMBER-TABLE 1

MOD CODE (6)

PLATING CODE NUMBER-TABLE 4 (6)

CABLE STRAIN-TABLE V (8)

CABLE ENTRY ORDER NUMBER-TABLE 2

Table 1 - Order Number Data

Accessory Order Number By Connector Code & Shell Size

ORDER NUMBER	MS3100 SERIES	MIL-DTL-3015 SOLDER CONTACT	MIL-DTL-26482 SERIES 1	MIL-DTL-22892 CLASS C, J & R	MIL-DTL-38999 SERIES III & IV	MIL-DTL-38999 SERIES I & II	MIL-DTL-5015 CRIMP	MIL-DTL-26482 SER 2	MIL-DTL-83723 SER III	MIL-C-81703 NAS 1599	LITTON VECAM CIR SERIES	MIL-C-81511 SERIES 1, 2, 3 & 4	PATT 105, PATT 603	PATT 608	ORDER NUMBER
	18 ④	21	32 ②	40 ③	41	54	64	61	76	A UNIFIED THREAD	B MAX DIA.	C MAX DIA.	D MAX DIM.	E MAX DIM.	
01	8S (B)														01
03	8S (A)														03
04	8S (C)	8			8, 9				8				.893	1.816	04
05						8 & 8S									05
06	10S (-)								8, A				1.462		06
07				9, A						M12 x 1.0	.719	.656	.893		07
08	10SL (C)	10			10, 11			3		10	.562-24	.844	.719		08
10	10SL(A,B), 12, 12S(B,C)					10, 10S, 10SL			12		.625-24	1.000	.781	.893	10
11									10, B		.625-28	1.000	.781	1.462	11
12				11, B							M15 x 1.0	.844	.781	.893	12
13	12 & 12S (A)	12			12, 13				12		.688-24	1.062	.844	.893	13
15	14 & 14S (-)		12			12 & 12S	7	14			.750-20	1.125	.906	1.369	15
16				13, C							M18 x 1.0	.969	.906	.893	16
18		14			14, 15				14		.812-20	1.188	.969		18
19	16 & 16S (-)		14			14 & 14S	12	16			.875-20	1.250	1.031	.981	19
20									14, D		.875-28	1.250	1.031	1.577	20
21				15, D							M22 x 1.0	1.094	1.031	.981	21
23		16			16, 17				16		.938-20	1.312	1.094		23
24	18 (-)		16			16 & 16S	19	18			1.000-20	1.375	1.156	1.230	24
25									16, E		1.000-28	1.375	1.156	1.824	25
26				17, E							M25 x 1.0	1.219	1.156	1.230	26
28		18			18, 19	18	27		18		1.062-18	1.438	1.219		28
29	20 (-)		18						20		1.125-18	1.500	1.281	1.202	29
30	20 (R)										1.125-24	1.500	1.281	2.016	30
31									18, F		1.125-28	1.500	1.281	1.796	31
32				19, F							M28 x 1.0	1.344	1.281	1.202	32
34		20			20, 21	20	37		20		1.188-18	1.562	1.344	1.223	34
35	22 (-)		20						22		1.250-18	1.625	1.406	2.016	35
36									20, G		1.250-28	1.625	1.406	1.807	36
37				21, G							M31 x 1.0	1.469	1.406	1.223	37
39		22			22, 23	22			22		1.312-18	1.688	1.469		39
40	24 (-)		22						24		1.375-18	1.750	1.531	1.181	40
41									22, H		1.375-28	1.750	1.531	1.775	41
42				23, H							M34 x 1.0	1.594	1.531	1.181	42
44		24			24, 25	24			24		1.438-18	1.812	1.594	1.181	44
45							61				1.500-18	1.875	1.656	2.016	45
46									24, J		1.500-28	1.875	1.656	1.775	46
47				25, J							M37 x 1.0	1.719	1.656	1.181	47

NOTES: UNLESS OTHERWISE SPECIFIED.

1 THREADS ARE RIGHT HAND IN ACCORDANCE WITH FED-STD-H28, CLASS 2B.

② THREADS NOTED ARE LEFT HAND, CLASS 2B.

③ THREADS NOTED ARE ISO METRIC, CLASS 6H.

④ CODE 18 SHELL SIZES ARE FOLLOWED IN PARENTHESIS BY CONNECTOR MFR CODE. SEE CONNECTOR CODE 18 CHART AT RIGHT & EXAMPLE PART NUMBER FOR DETAILS.

5 TABLE 1 LISTS THE MOST USED CONNECTOR CODES. SEE SECTION 11 FOR OTHER CODES AVAILABLE AND COMPLETE CONNECTOR PART NUMBER CROSS REFERENCE.

⑥ SEE SUPPORT DATA SECTION FOR PLATING AND MODIFICATION CODE OPTIONS.

⑦ ADD .25 TO "D" & "F" FOR CONNECTOR CODES 30, 32 & 61.

⑧ SEE SUPPORT DATA SECTION FOR TABLE V & AVAILABLE STYLES

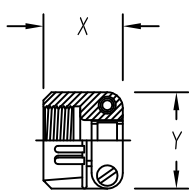
④ Connector Code 18 Chart

CONNECTOR CODE	CONNECTOR MANUFACTURER
	(MS3100, MS3101, MS3106 & MS3107)
A	AMPHENOL, CLASS A
B	BENDIX, CLASS A, E & R
C	CANNON, CLASS A, E & R
D	MFR. UNKNOWN, CLASS A, E & R
R	AMPHENOL, CLASS R
-	MFR. CODE NOT REQUIRED

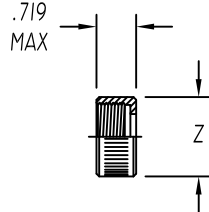


Table 2 - Environmental / Non-Environmental Cable Entry Data

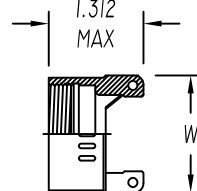
ENTRY ORDER NUMBER	ENVIRONMENTAL		NON ENVIRONMENTAL		V UNIFIED THREAD	R MAX DIM.	S MAX DIM.	T MAX DIM.	U MAX DIM.	W MAX DIM.	X MAX DIM.	Y MAX DIM.	Z MAX DIA.
	GLAND RANGE		CABLE RANGE										
	MAX	MIN	MAX	MIN									
△ 03	.250	.156	.250	.156	.500-28	N / A	.812	1.375	.812	N / A	.844	.781	.656
04	.312	.188	.312	.188	.625-24	1.031	.937	1.375	.937	.875	.844	.906	.781
06	.438	.281	.438	.281	.750-20	1.031	1.062	1.375	1.062	1.000	.906	1.094	.906
08	.562	.375	.562	.344	.875-20	1.031	1.188	1.375	1.188	1.125	.969	1.188	1.031
10	.625	.500	.625	.375	1.000-20	1.094	1.312	1.437	1.312	1.250	.969	1.281	1.156
12	.750	.500	.750	.438	1.188-18	1.219	1.562	1.437	1.562	1.375	.969	1.500	1.344
△ 14	.875	.750	.875	.719	1.250-18	N / A	N / A	N / A	N / A	1.500	N / A	N / A	N / A
16	1.000	.844	1.000	.781	1.438-18	1.219	1.750	1.562	1.750	1.625	1.062	1.719	1.594
20	1.250	.938	1.250	.750	1.750-18	1.344	2.250	1.812	2.250	1.750	1.125	2.062	1.906
24	1.375	1.000	1.375	.781	2.000-18	N / A	2.375	2.062	2.375	N / A	1.188	2.312	2.156
28	1.625	1.250	1.625	.969	2.250-16	N / A	2.625	2.062	2.625	N / A	1.719	2.719	2.406
32	1.875	1.500	1.875	1.125	2.500-16	N / A	2.812	2.188	2.812	N / A	1.781	2.969	2.656



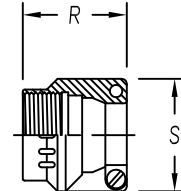
STYLE 1 △
 AS85049/41A CLAMP
 (MS 3057**A)



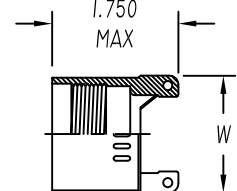
STYLE 2 △
 NUT



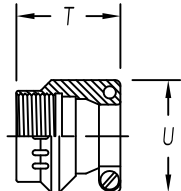
STYLE 3 △
 NON-ENVIRONMENTAL



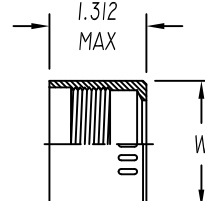
STYLE 3 △
 NUT ENVIRONMENTAL
 (AS85049/1)
 (MS 3057-**B)



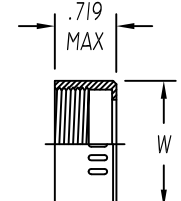
STYLE 3 △
 ENVIRONMENTAL



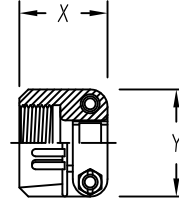
STYLE 4 △
 STRAIN RELIEF ENVIRONMENTAL
 (AS85049/2)
 (MS 3057-**C)



STYLE 4 △
 ENVIRONMENTAL



STYLE 4 △
 NON-ENVIRONMENTAL



STYLE 9 △
 STRAIN-RELIEF CLAMP WITH TELESCOPING SCREWS

NOTES: UNLESS OTHERWISE SPECIFIED

△1 AVAILABLE ONLY ON: A**01, A**30, E**01, E**03, E**04, E**05, E**07, E**21, E**30, & E**33

△2 AVAILABLE ONLY ON: E**15, E**17, E**38, E**40, & E**41

3. CONSULT FACTORY FOR SIZES AND INFORMATION NOT LISTED