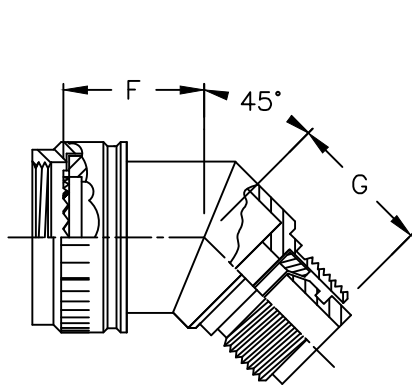




Table 2 - Cable Entry Data

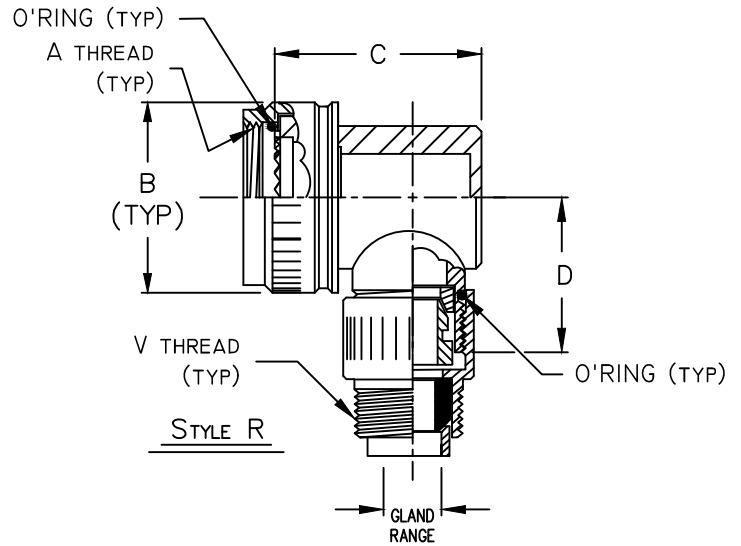
ENTRY ORDER NUMBER	ENVIRONMENTAL GLAND RANGE		NON ENVIRONMENTAL CABLE RANGE		UNIFIED THREAD
	MAX	MIN	MAX	MIN	
03	.250	.156	.250	.156	.500-28
04	.312	.188	.312	.188	.625-24
06	.438	.281	.438	.281	.750-20
08	.562	.375	.562	.344	.875-20
10	.625	.500	.625	.375	1.000-20
12	.750	.500	.750	.438	1.188-18
16	.938	.625	.938	.562	1.438-18
20	1.250	.938	1.250	.750	1.750-18
24	1.375	1.000	1.375	.781	2.000-18
28	1.625	1.250	1.625	.969	2.250-16
32	1.875	1.500	1.875	1.125	2.500-16

WHEN MAXIMUM CABLE ENTRY EXCEEDS THE CONNECTOR INTERFACE DIAMETER, A 2 PIECE ADAPTER WILL BE SUPPLIED.



STYLE A

Non-Environmental Assembly Shown



STYLE R

ASSEMBLY PART NUMBER

TO ESTABLISH YOU P/N, USE THE FOLLOWING EXAMPLE

E 41 33 S 23 08 9 B 51

FUNCTION DESIGNATOR
E-EMI ADAPTER

CONNECTOR CODE NUMBER - TABLE 1

SERIES PART NUMBER

ADAPTER STYLE
R = 90° ADAPTER
A = 45° ADAPTER

ACCESSORY ORDER NUMBER-TABLE 1

CABLE ENTRY ORDER NUMBER-TABLE 2

MOD CODE

PLATING CODE NUMBER-TABLE 4

GLAND & O-RING MATERIAL OPTION
B - NEOPRENE & BUNA-N
S - SILICONE
N - NONE REQUIRED (NON ENVIRONMENTAL)

CABLE STRAIN RELIEF - SEE TABLE V

Table 1 - Order Number Data

Accessory Order Number By Connector Code & Shell Size

ORDER NUMBER	Accessory Order Number By Connector Code & Shell Size										A UNIFIED THREAD	B MAX DIA.	C (7) MAX DIM.	D MAX DIM.	F (7) ±.125 DIM.	G MAX DIM.	ORDER NUMBER
	18 ④	21	32 ②	40 ③	41	54	64	61	76								
01	8S (B)										.375-32	.750	1.031		.500		01
03	8S (A)										.438-27	.812	1.094		.500		03
04	8S (C)	8			8, 9				8		.438-28	.812	1.000	1.188	.750		04
05								8 & 8S			.500-20	.875	.938		.719	1.062	05
06	10S (-)								8, A		.500-28	.875	1.562		1.062		06
07				9, A						M12 x 1.0	.719	.938	1.250	.500			07
08	10SL (C)	10			10, 11					3	.562-24	.844	1.375		.750		08
10	10SL(A,B), 12, 12S(B,C)							10, 10S, 10SL		12	.625-24	1.000	1.562		1.062		10
11									10, B		.625-28	1.000	1.688	1.312	1.062	1.094	11
12				11, B							M15 x 1.0	.844	1.125		.500		12
13	12 & 12S (A)	12			12, 13					12	.688-24	1.062	1.500		.750		13
15	14 & 14S (-)		12			12 & 12S	7	14			.750-20	1.125	1.812		.875		15
16				13, C							M18 x 1.0	.969	1.188	1.375	.562	1.125	16
18		14			14, 15					14	.812-20	1.188	1.500		.812		18
19	16 & 16S (-)		14			14 & 14S	12	16			.875-20	1.250	1.875		.750		19
20									14, D		.875-28	1.250	1.938	1.438	1.125		20
21				15, D							M22 x 1.0	1.094	1.312		.562		21
23		16			16, 17					16	.938-20	1.312	1.625		.875		23
24	18 (-)		16			16 & 16S	19	18			1.000-20	1.375	2.000		.719		24
25										16, E	1.000-28	1.375	2.062	1.500	1.156		25
26				17, E							M25 x 1.0	1.219	1.438		.594	1.188	26
28		18			18, 19	18	27			18	1.062-18	1.438	1.688		.875		28
29	20 (-)		18							20	1.125-18	1.500	2.156		.938		29
30	20 (R)										1.125-24	1.500	1.938	1.562	.625		30
31									18, F		1.125-28	1.500	2.125		1.188		31
32				19, F							M28 x 1.0	1.344	1.500		.625		32
34		20			20, 21	20	37			20	1.188-18	1.562	1.812		.875		34
35	22 (-)		20							22	1.250-18	1.625	2.250		.938		35
36									20, G		1.250-28	1.625	2.250	1.625	1.250		36
37				21, G							M31 x 1.0	1.469	1.625		.688	1.219	37
39		22			22, 23	22				22	1.312-18	1.688	1.938		.938		39
40	24 (-)		22							24	1.375-18	1.750	2.375		1.000		40
41									22, H		1.375-28	1.750	2.375		1.250		41
42				23, H							M34 x 1.0	1.594	1.750		.656	1.250	42
44		24			24, 25	24				24	1.438-18	1.812	2.000	1.688	1.000		44
45							61				1.500-18	1.875	1.875		.938	1.438	45
46									24, J		1.500-28	1.875	2.500		1.250		46
47				25, J							M37 x 1.0	1.719	1.875		.688	1.250	47
48											1.562-18	1.938	2.125		1.062		48
49	28 (-)		24						28		1.625-18	2.000	2.500	1.812	1.250	1.312	49
51						28					1.750-18	2.125	2.062		.938		51
52	32 (B,C)		28							32	1.875-16	2.250	2.750	1.938	1.125	1.344	52
53	32 (A,R)										1.906-18	2.281	2.438		.750		53
54						32					2.000-18	2.375	2.312		.969		54
55	36 (B)		32							36	2.062-16	2.469	3.000		.969		55
56	36 (R)										2.062-24	2.469	1.875	2.062	.812	1.406	56
57	36 (C)										2.125-16	2.500	1.875		.812		57
58	36 (A)										1.125-18	2.500	1.875		.812		58
59						36					2.250-16	2.625	2.438		1.031		59
60	40 (B)		36							40	2.312-16	2.719	3.250	2.188	1.000	1.438	60
61	40 (A,C)										2.375-16	2.750	2.000		.875		61
62						40					2.500-16	2.875	2.688	2.750	1.125	1.500	62

NOTES: UNLESS OTHERWISE SPECIFIED.

1 THREADS ARE RIGHT HAND IN ACCORDANCE WITH FED-STD-H28, CLASS 2B.

② THREADS NOTED ARE LEFT HAND, CLASS 2B.

③ THREADS NOTED ARE ISO METRIC, CLASS 6H.

④ CODE 18 SHELL SIZES ARE FOLLOWED IN PARENTHESIS BY CONNECTOR MFR CODE. SEE CONNECTOR CODE 18 CHART AT RIGHT & EXAMPLE PART NUMBER FOR DETAILS.

5 TABLE 1 LISTS THE MOST USED CONNECTOR CODES. SEE SECTION 11 FOR OTHER CODES AVAILABLE AND COMPLETE CONNECTOR PART NUMBER CROSS REFERENCE.

⑥ SEE SUPPORT DATA SECTION FOR PLATING AND MODIFICATION CODE OPTIONS.

⑦ ADD .25 TO "D" & "F" FOR CONNECTOR CODES 30, 32 & 61.

⑧ SEE SUPPORT DATA SECTION FOR TABLE V & AVAILABLE STYLES

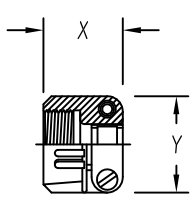
④ Connector Code 18 Chart

CONNECTOR CODE	CONNECTOR MANUFACTURER (MS3100, MS3101, MS3106 & MS3107)
A	AMPHENOL, CLASS A
B	BENDIX, CLASS A, E & R
C	CANNON, CLASS A, E & R
D	MFR. UNKNOWN, CLASS A, E & R
R	AMPHENOL, CLASS R
-	MFR. CODE NOT REQUIRED

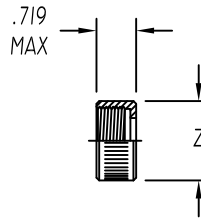


Table 2 - Environmental / Non-Environmental Cable Entry Data

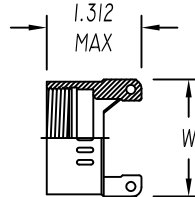
ENTRY ORDER NUMBER	ENVIRONMENTAL		NON ENVIRONMENTAL		V UNIFIED THREAD	R MAX DIM.	S MAX DIM.	T MAX DIM.	U MAX DIM.	W MAX DIM.	X MAX DIM.	Y MAX DIM.	Z MAX DIA.
	GLAND RANGE		CABLE RANGE										
	MAX	MIN	MAX	MIN									
△ 03	.250	.156	.250	.156	.500-28	N / A	.812	1.375	.812	N / A	.844	.781	.656
04	.312	.188	.312	.188	.625-24	1.031	.937	1.375	.937	.875	.844	.906	.781
06	.438	.281	.438	.281	.750-20	1.031	1.062	1.375	1.062	1.000	.906	1.094	.906
08	.562	.375	.562	.344	.875-20	1.031	1.188	1.375	1.188	1.125	.969	1.188	1.031
10	.625	.500	.625	.375	1.000-20	1.094	1.312	1.437	1.312	1.250	.969	1.281	1.156
12	.750	.500	.750	.438	1.188-18	1.219	1.562	1.437	1.562	1.375	.969	1.500	1.344
△ 14	.875	.750	.875	.719	1.250-18	N / A	N / A	N / A	N / A	1.500	N / A	N / A	N / A
16	1.000	.844	1.000	.781	1.438-18	1.219	1.750	1.562	1.750	1.625	1.062	1.719	1.594
20	1.250	.938	1.250	.750	1.750-18	1.344	2.250	1.812	2.250	1.750	1.125	2.062	1.906
24	1.375	1.000	1.375	.781	2.000-18	N / A	2.375	2.062	2.375	N / A	1.188	2.312	2.156
28	1.625	1.250	1.625	.969	2.250-16	N / A	2.625	2.062	2.625	N / A	1.719	2.719	2.406
32	1.875	1.500	1.875	1.125	2.500-16	N / A	2.812	2.188	2.812	N / A	1.781	2.969	2.656



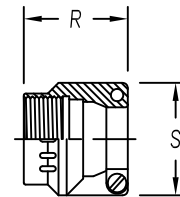
STYLE 1 △
 AS85049/41A CLAMP
 (MS 3057**A)



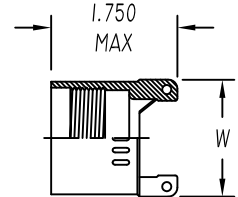
STYLE 2 △
 NUT



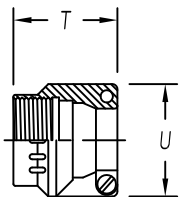
STYLE 3 △
 NON-ENVIRONMENTAL



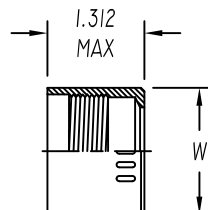
STYLE 3 △
 NUT ENVIRONMENTAL
 (AS85049/1)
 (MS 3057-**B)



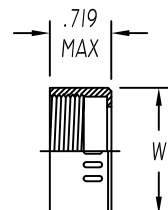
STYLE 3 △
 ENVIRONMENTAL



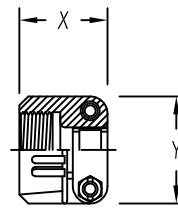
STYLE 4 △
 STRAIN RELIEF ENVIRONMENTAL
 (AS85049/2)
 (MS 3057-**C)



STYLE 4 △
 ENVIRONMENTAL



STYLE 4 △
 NON-ENVIRONMENTAL



STYLE 9 △
 STRAIN-RELIEF CLAMP WITH TELESCOPING SCREWS

NOTES: UNLESS OTHERWISE SPECIFIED

△1 AVAILABLE ONLY ON: A**01, A**30, E**01, E**03, E**04, E**05, E**07, E**21, E**30, & E**33

△2 AVAILABLE ONLY ON: E**15, E**17, E**38, E**40, & E**41

3. CONSULT FACTORY FOR SIZES AND INFORMATION NOT LISTED