

STYLE A, F OR G  
SEE PART NUMBER

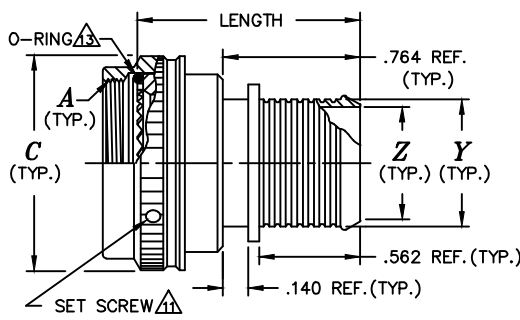

STYLE S

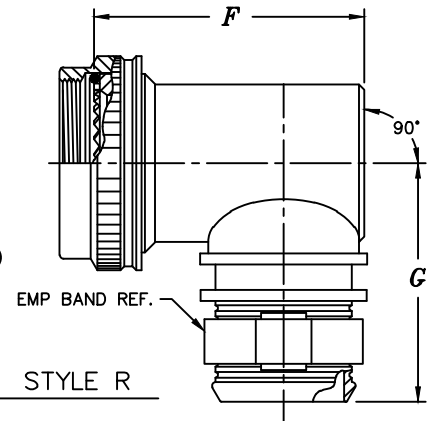

STYLE R

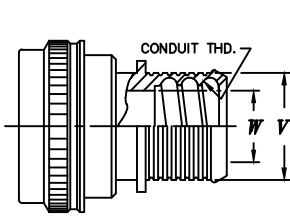

MODIFICATION C  
(HELICAL CONDUIT THREAD)

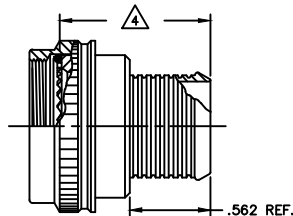

MODIFICATION Z  
(LESS BOOT GROOVE)

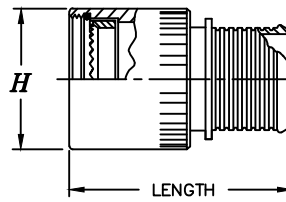

STYLE B

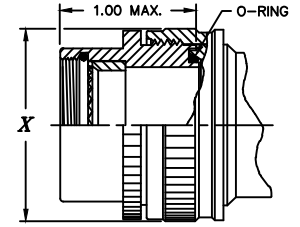

2 PIECE  $\Delta$

*Example Part Number*

21741S161030855H

BASIC ADAPTER NUMBER

STYLE  
 S = STRAIGHT F = 30°  
 A = 45° G = 60°  
 R = 90° B = BASIC

ORDER NO. PER TABLE II

MODIFICATION CODE  $\Delta$   
 S = SELF LOCKING ROUND COUPLING.  
 Z = LESS BOOT GROOVE, OMIT FOR STANDARD BOOT GROOVE  $\Delta$   
 C = HELICAL CONDUIT THREAD

PLATING CODE NUMBER  
 55 = CADMIUM, OLIVE DRAB, PER SAE-AMSQQ-P-416, TYPE II, CLASS 3, OVER ELECTROLESS NICKEL PER AMS-C-26074, CLASS 3 OR 4, GRADE B  
 56 = ELECTROLESS NICKEL PER SAE-AMS-2404F, WITH IRIDITE CONVERSION  
 FOR ADDITIONAL FINISH OPTIONS, SEE CATALOG TABLE 4.

LENGTH CODE NUMBER  
 SELECT LENGTH IN 1/4" INCREMENTS (ie; 08=2.00", 09=2.25", etc.)  
 00 FOR 45° & 90° ADAPTERS ( STYLES A & R )

MIN. AVAIL. LENGTH	CONNECTOR CODES (TABLE I)
1.250 $\Delta$ $\Delta$	18, 21, 40, 41, 47, 51, 52, 54, 55, 71
1.500 $\Delta$ $\Delta$	24, 30, 32, 61, 64

TERMINATION NUMBER  
 1 = ADAPTER ONLY  
 4 = ADAPTER w/ 1/4" EMP BAND (REF. 214L0002)  
 5 = ADAPTER w/ 1/4" EMP BAND AND SHRINK BOOT  
 6 = ADAPTER w/ 1/8" EMP BAND (ENTRY 13-24 CUSTOMER SUPPLIED)  
 7 = ADAPTER w/ 1/8" EMP BAND (ENTRY 13-24 CUSTOMER SUPPLIED)  
 8 = ADAPTER w/ 1/8" EMP BAND (REF. 214L0005)  
 9 = ADAPTER w/ 1/4" EMP BAND (A10086)



MILITARY SPECIFICATION	SERIES	CODE NO.
MIL-DTL-5015D	3100	1 8
MIL-DTL-83723	II	1 9
MIL-DTL-26482	1	2 1
MIL-DTL-26482	1 (07)	2 4
MIL-DTL-28840	-	3 0
MIL-DTL-22992	-	3 2
MIL-DTL-38999	III & IV	40 $\Delta$
MIL-DTL-38999	I & II	41 $\Delta$
LN 29729, PATT 615, PAN 6433-2,	-	47
MIL-DTL-26500	(ALUMINUM)	5 1
MIL-DTL-5015G	3400	54 $\Delta$
MIL-C-81703	3	54 $\Delta$
MIL-DTL-83723	I	54 $\Delta$
MIL-DTL-26482	2	54 $\Delta$
MIL-DTL-83723	III	54 $\Delta$
NAS1599	-	54 $\Delta$
MIL-C-81511	1, 2, 3 & 4	6 1
PATT 105, PATT 603, PATT 608	-	76

ENTRY ORDER NO.	EMP BAND			HELICAL CONDUIT		
	Z +.010 -.020 DIA.	Y .±.015 DIA.	X MAX DIA.	CONDUIT THREAD SIZE	W REF. DIA.	V ±.015 DIA.
0 2	.125	.209	N/A	N/A	N/A	N/A
0 3	.188	.271	N/A	N/A	N/A	N/A
0 4	.250	.334	N/A	N/A	N/A	N/A
0 5	.312	.396	.734	0188	.188	.413
0 6	.375	.459	.734	0281	.281	.507
0 7	.438	.521	.858	0312	.312	.531
0 8	.500	.584	.858	0375	.375	.603
0 9	.562	.646	N/A	0438	.438	.664
1 0	.625	.709	1.112	0500	.500	.743
1 2	.750	.834	1.345	0625	.625	.863
1 4	.875	.959	1.345	N/A	N/A	N/A
1 6	1.000	1.084	1.594	0750	.750	1.023
1 8	1.125	1.209	1.594	0875	.875	1.166
1 9	1.188	1.209	1.594	N/A	N/A	N/A
2 0	1.250	1.334	1.969	1000	1.000	1.319
2 2	1.375	1.459	2.219	N/A	N/A	N/A
2 4	1.500	1.584	2.219	1250	1.250	1.632



\* THIS DOCUMENT INCOMPLETE WITHOUT "INTERFACE SPECIFICATION SHEET".



**TABLE II – CONNECTOR CODE 40  
 MIL-DTL-38999, SERIES III&IV**

ORDER NO.	SHELL SIZE		<i>A</i> METRIC THD. CLASS 6H	$\phi C$ MAX.	<i>D</i> MAX.	<i>E</i> MAX. 	<i>F</i> MAX.	<i>G</i> MAX. 	$\phi H$ $\pm .031$	BAND MAX. 1 PIECE ENTRY	MOD. C MAX. 1 PIECE ENTRY
	COM'L.	MIL.									
0 8	9	A	M12 x 1.0	.703	.52	1.15	.84	1.28	.625	0 4	0 5
1 0	11	B	M15 x 1.0	.827	.54	1.17	.97	1.34	.750	0 6	0 8
1 2	13	C	M18 x 1.0	.953	.57	1.20	1.09	1.41	.875	0 8	1 0
1 4	15	D	M22 x 1.0	1.077	.59	1.23	1.22	1.47	1.000	1 0	1 2
1 6	17	E	M25 x 1.0	1.203	.62	1.25	1.34	1.53	1.125	1 2	1 6
1 8	19	F	M28 x 1.0	1.327	.63	1.26	1.41	1.59	1.250	1 3	1 6
2 0	21	G	M31 x 1.0	1.453	.66	1.29	1.53	1.66	1.375	1 5	1 8
2 2	23	H	M34 x 1.0	1.577	.68	1.32	1.66	1.72	1.500	1 7	2 0
2 4	25	J	M37 x 1.0	1.703	.71	1.34	1.78	1.78	1.625	1 9	2 0

NOTES:

1. ASSEMBLY IDENT. PER MIL-STD-1285.
2. MATERIAL: COMPONENTS – ALUM. ALLOY  
O’RING – SILICONE
-  "2 PIECE" CONFIG. SUPPLIED WHEN CABLE ENTRY DIA. EXCEEDS CONN. INSERT DIA..
-  DIMENSIONS INDICATED WILL BE .20" LESS WHEN ORDERED WITH MOD. CODE Z.
-  FOR MULTIPLE MOD. CODES USE SEQUENCE SHOWN.



**TABLE II — CONNECTOR CODE 41  
 MIL-DTL-38999, SERIES I & II**

ORDER NO.	SHELL SIZE		<i>A</i> UNIFIED THD. CLASS 2B	$\phi C$ MAX.	<i>D</i> MAX.	<i>E</i> MAX. $\triangle 4$	<i>F</i> MAX.	<i>G</i> MAX. $\triangle 4$	$\phi H$ $\pm .031$	BAND MAX. 1 PIECE ENTRY	MOD. C MAX. 1 PIECE ENTRY
	SER. II	SER. I									
0 8	8	9	.438-28	.703	.52	1.15	.84	1.28	.562	0 4	0 5
1 0	10	11	.562-24	.827	.54	1.17	.97	1.34	.688	0 6	0 8
1 2	12	13	.688-24	.953	.57	1.20	1.09	1.41	.812	0 8	1 0
1 4	14	15	.812-20	1.077	.59	1.23	1.22	1.47	.938	1 0	1 2
1 6	16	17	.938-20	1.203	.62	1.25	1.34	1.53	1.062	1 2	1 6
1 8	18	19	1.062-18	1.327	.63	1.26	1.41	1.59	1.188	1 3	1 6
2 0	20	21	1.188-18	1.453	.66	1.29	1.53	1.66	1.312	1 5	1 8
2 2	22	23	1.312-18	1.577	.68	1.32	1.66	1.72	1.438	1 7	2 0
2 4	24	25	1.438-18	1.703	.71	1.34	1.78	1.78	1.562	1 9	2 0

NOTES:

1. ASSEMBLY IDENT. PER MIL-STD-1285.
2. MATERIAL: COMPONENTS — ALUM. ALLOY  
 O’RING — SILICONE

$\triangle 3$  "2 PIECE" CONFIG. SUPPLIED WHEN CABLE  
 ENTRY DIA. EXCEEDS CONN. INSERT DIA..

$\triangle 4$  DIMENSIONS INDICATED WILL BE .20" LESS  
 WHEN ORDERED WITH MOD. CODE Z.

$\triangle 5$  FOR MULTIPLE MOD. CODES USE SEQUENCE  
 SHOWN.



TABLE II — CONNECTOR CODE 54

MIL-DTL-26482, SERIES 2  
 MIL-DTL-5015G, 3400 SERIES  
 MIL-C-81703, SERIES 3  
 MIL-DTL-83723, SERIES I & III  
 NAS1599

ORDER NO.	SHELL SIZE		A UNIFIED THD. CLASS 2B	øC MAX.	D MAX.	E MAX. 4 6	F MAX.	G MAX. 4 6	øH ø.031	BAND MAX. 1 PIECE ENTRY	MOD. C MAX. 1 PIECE ENTRY
	8	7									
0 3	3	-	.562-24	.669	.55	1.15	.84	1.28	.688	0 4	0 5
0 8	-	8,8S	.500-20	.617	.55	1.15	.84	1.28	.625	0 4	0 5
1 0	-	10,10S,10SL	.625-24	.734	.57	1.17	.97	1.31	.750	0 6	0 7
1 2	7	12,12S	.750-20	.858	.60	1.20	1.09	1.38	.875	0 8	1 0
1 4	12	14,14S	.875-20	.984	.61	1.21	1.16	1.44	1.000	0 8	1 0
1 6	19	16,16S	1.000-20	1.112	.64	1.24	1.28	1.50	1.125	1 0	1 2
1 8	27	18	1.062-18	1.218	.65	1.25	1.34	1.53	1.188	1 2	1 6
2 0	37	20	1.188-18	1.345	.68	1.28	1.47	1.59	1.312	1 4	1 8
2 2	-	22	1.312-18	1.468	.70	1.30	1.59	1.66	1.438	1 6	2 0
2 4	-	24	1.438-18	1.593	.73	1.33	1.72	1.72	1.562	1 8	2 0
2 8	-	28	1.750-18	1.969	.78	1.38	1.97	1.88	1.875	2 0	2 4
3 2	-	32	2.000-18	2.219	.83	1.43	2.22	2.00	2.125	2 4	2 4
3 6	-	36	2.250-16	2.469	.86	1.46	2.34	2.13	2.375	2 4	2 4
4 0	-	40	2.500-16	2.719	.91	1.51	2.59	2.25	2.625	2 4	2 4
4 4	-	44	2.750-16	2.969	.96	1.56	2.84	2.38	2.875	2 4	2 4
4 8	-	48	3.000-16	3.219	1.01	1.61	3.09	2.50	3.125	2 4	2 4
6 1	61	-	1.500-18	1.653	.74	1.34	1.78	1.75	1.625	1 8	2 0

NOTES:

1. ASSEMBLY IDENT. PER MIL-STD-1285.
2. MATERIAL: COMPONENTS — ALUM. ALLOY  
O'RING — SILICONE

△ SIZES PER MIL-C-81703, SERIES 3.

- 3 "2 PIECE" CONFIG. SUPPLIED WHEN CABLE ENTRY DIA. EXCEEDS CONN. INSERT DIA..
- 4 DIMENSIONS INDICATED WILL BE .20" LESS WHEN ORDERED WITH MOD. CODE Z.
- 5 FOR MULTIPLE MOD. CODES USE SEQUENCE SHOWN.
- 6 FOR MODIFICATION C AND ENTRY 24, ADD .188" TO LENGTH SHOWN.
- 7 SIZES PER MIL-DTL-5015 (3400 SERIES), MIL-DTL-26482 (SERIES 2), MIL-DTL-83723 (SERIES I & III), & NAS1599.



**STANDARD FINISHES**

PLATING CODE	FINISH	SPECIFICATION	ACCESSORY MATERIAL	CORROSION RESISTANCE (HRS)	ROHS COMPLIANT
0 3	CADIUM PLATE, OLIVE DRAB	SAE AMS-QQ-P-416, TYPE II, CLASS 3	ALUMINUM	96	NO
1 0	PASSIVATE	SAE AMS-QQ-P-35, (AS85049 CODE S)	STAINLESS STEEL	1000	YES
1 2	ZINC NICKEL, BLACK	ASTM B841	ALUMINUM	500	YES
1 3	ZINC COBALT, OLIVE DRAB	ASTM B840-99	ALUMINUM	96	NO
1 4	ZINC COBALT, BLACK	ASTM B840-99	ALUMINUM	96	NO
2 1	IRIDITE, 14-2, GOLD	IRIDITE, NUMBER 14-2 PER MIL-DTL-5541 CL 3	ALUMINUM	96	NO
3 4	ANODIZE, BLACK	MIL-A-8625, TYPE II, CL 3 (AS85049 CODE A)	ALUMINUM	1000	YES
3 5	ANODIZE ,GREY	MIL-A-8625, TYPE II, CLASS 2	ALUMINUM	500	YES
4 4	ANODIZE, HARD, BLACK	MIL-A-8625, TYPE II, CLASS 2	ALUMINUM	500	YES
4 5	ANODIZE, HARD, GREY	MIL-A-8625, TYPE II, CLASS 2	ALUMINUM	1000	YES
4 8	ELECTROLESS NICKEL	AMS-2404F, CLASS 4, GRADE B	STAINLESS STEEL	48	NO
5 1	ELECTROLESS NICKEL	AMS-2404F, CLASS 4, GRADE B	ALUMINUM	48	NO
5 5	CADIUM PLATE, OLIVE DRAB, OVER ELECTROLESS NICKEL	SAE AMS-QQ-P-416, TYPE II, CLASS 3, OVER ELECTROLESS NICKEL, PER AMS-2404F (AS85049 CODE W)	ALUMINUM	1000	NO
5 6	ELECTROLESS NICKEL	AMS-2404F, CLASS 4, GRADE A	ALUMINUM	96	NO
5 6 R	ELECTROLESS NICKEL	AMS-2404F, CLASS 4, GRADE A	ALUMINUM	48	YES
5 7	ELECTROLESS NICKEL	AMS-2404F, CLASS 4, GRADE A (AS85049 CODE N)	ALUMINUM	96	NO
64	CADIUM PLATE, OLIVE DRAB, OVER ELECTROLESS NICKEL	SAE AMS-QQ-P-416, TYPE II, CLASS 3, OVER  ELECTROLESS NICKEL, PER AMS-2404F (SELECTIVE PLATING REF AS85049 CODE P)	ALUMINUM	1000	NO
85	PASSIVATED	SAE AMS-QQ-P-35	316 SST	1000	YES
87	BEAD BLASTED	N/A	NI. ALUM. BRONZE	1000	YES

NOTES: UNLESS OTHERWISE SPECIFIED

1. CORROSION RESISTANCE IS SPECIFIED FOR SALT SPRAY IN ACCORDANCE WITH AS85049

CONSULT FACTORY FOR OTHER FINISHES

FINISHES ARE APPLICABLE TO THE CONNECTOR ACCESSORIES ONLY AND EXCLUDE FASTENERS AND OTHER HARDWARE

4. EMI/RFI ACCESSORIES ARE SUPPLIED WITH CONDUCTIVE FINISHES ONLY

5. ANODIZE NOT SUITABLE FOR EMI SHIELDING OR GROUNDING APPLICATIONS

6. ALL THE CONDUCTIVE FINISHES USED ON ALUMINUM CAN ALSO BE USED ON BRASS (CONSULT FACTORY)

CADMIUM/NICKEL INTERFACE SHALL BE COATED WITH POLYSULFIDE SEALANT (REF FIGURE 2 BELOW)

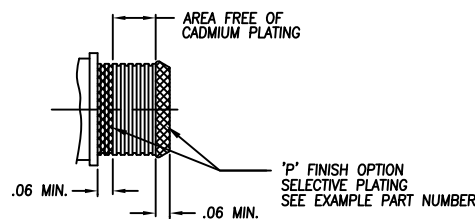

**FIGURE 2**



**STANDARD MATERIALS**

COMPONENT	MATERIAL	SPECIFICATION
MACHINED COMPONENTS	ALUMINUM STAINLESS STEEL (300 SERIES) BRASS NICKEL ALUMINUM BRONZE	ASTM B221, ASTM B211 (MFG OPTION) AMS-QQ-S-763, QQ-S-764 (MFG OPTION) QQ-B-626 ASTMB150 (AMS4640)
DIE CAST COMPONENTS	ALUMINUM	ASTM B 85
FASTENERS AND HARDWARE	STAINLESS STEEL (300 SERIES) STEEL BRASS	AMS-QQ-S-763 SAE20, QQ-S-634, QQ-S-637 QQ-B-626
ELASTOMERIC SEALS	SILICONE BUNA-N NEOPRENE	ZZ-R-765B, MIL-R-25988 AMS-3209 MIL-R-3065

NOTES: UNLESS OTHERWISE SPECIFIED

1. THE SPECIFIED MATERIALS ARE STANDARD FOR THE MAJORITY OF CONNECTOR ACCESSORIES
2. CONSULT FACTORY FOR OTHER MATERIALS
3. FOR DOCUMENTS LISTED WITHIN THIS CATALOG WITH OUT A TOLERANCE SHOWN SHALL HAVE TOLERANCES AS FALLOWED:
  - .X =  $\pm .2$
  - .XX =  $\pm .12$
  - .XXX =  $\pm .062$
  - X° =  $\pm 10^\circ$