



ELECTRO ADAPTER, INC.
 CHATSWORTH, CALIFORNIA, USA 91311
 PHONE: (818) 998-1198
 FAX: (818) 709-5773
 www.electro-adapter.com

**CONSTANT FORCE SPRING
 ADAPTER FOR
 MIL-DTL-38999, SERIES III & IV**

SPECIFICATION CONTROL DRAWING

901-423

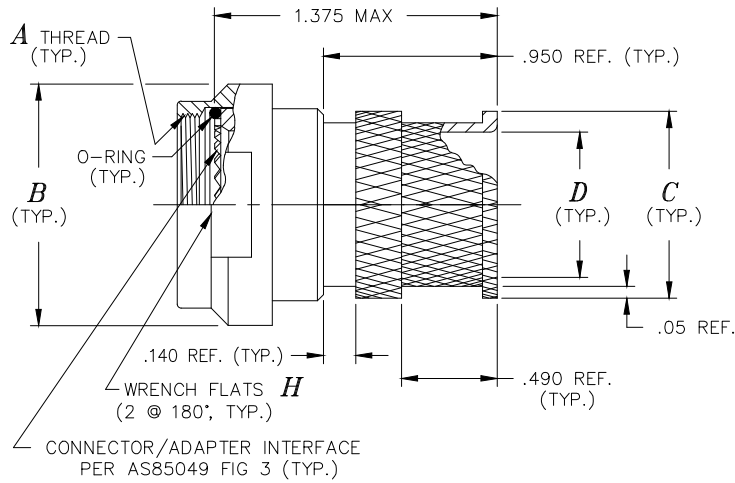

STYLE S

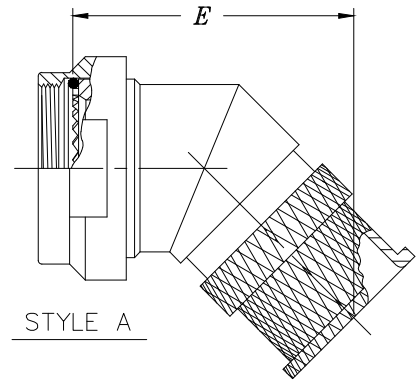

STYLE A

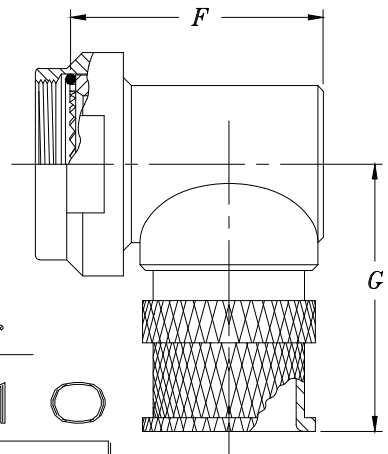

STYLE R

Example Part Number

901-423S210

BASIC ADAPTER NUMBER

ADAPTER STYLE

STYLE S = STRAIGHT ADAPTER
 STYLE A = 45° ADAPTER
 STYLE R = 90° ADAPTER

PLATING CODE NUMBER

10 = PASSIVATE, PER SAE-AMS-QQ-P-35
 12 = BLACK, ZINC NICKEL, TYPE II, CLASS 2
 55 = CADMIUM, OLIVE DRAB, PER SAE AMS-QQ-P-416, TYPE II, CLASS 3,
 OVER ELECTROLESS NICKEL PER AMS-C-26074, CLASS 3 OR 4, GRADE B
 56 = ELECTROLESS NICKEL PER SAE AMS-2404F, CLASS 3 OR 4, GRADE A.

FOR ADDITIONAL FINISH OPTIONS, SEE CATALOG TABLE 4.

NOTES:

- ASSEMBLY IDENT. PER MIL-STD-1285.
- MATERIAL: COMPONENTS - ALUMINUM ALLOY, 300 SERIES STAINLESS STEEL. O-RING - SILICONE
- SEE DRAWING NUMBER 901-436 FOR SHIELD TERMINATION SPRING. (TACOM DWG#12347630)
- QUALIFIED TO TACOM DRAWINGS NO'S
 45° ~ 12387118
 45° ~ 12387117
 90° ~ 12387119

ADAPTER DATA

ORDER NUMBER	SHELL SIZE		A METRIC THD. CLASS 6H	B MAX. DIA.	C MAX. DIA.	D REF. DIA.	E REF.	F REF.	G REF.	H ACROSS FLATS
	COM'L.	MIL.								
1	9	A	M12 x 1.0	.78	.53	.25	1.57	.81	1.344	.625
2	11	B	M15 x 1.0	.91	.61	.37	1.59	.93	1.406	.750
3	13	C	M18 x 1.0	1.03	.78	.50	1.63	1.06	1.469	.875
4	15	D	M22 x 1.0	1.16	.84	.62	1.67	1.18	1.531	1.000
5	17	E	M25 x 1.0	1.28	.96	.75	1.71	1.31	1.594	1.125
6	19	F	M28 x 1.0	1.41	1.04	.81	1.77	1.37	1.656	1.250
7	21	G	M31 x 1.0	1.53	1.22	1.00	1.81	1.50	1.719	1.375
8	23	H	M34 x 1.0	1.66	1.35	1.12	1.84	1.62	1.781	1.500
9	25	J	M37 x 1.0	1.78	1.48	1.25	1.90	1.68	1.844	1.625